

Flanged gate valves, designed according to EN1074 part 1 & 2, Face to face according to EN 558 table 2 basic series 3.
Standard flange drilling to EN1092-2 (ISO 7005-2)

Use: For water, sewage and neutral liquids to max. 70°C
Hydraulic tests: Seat: 1.1 x PN. Body: 1.5 x PN
Applicable Standards: To EN 1074 Part 1 & 2 : 2000
Options: Stemcap
 Handwheel
 Bevel or spur gearbox
 Extension spindle
 Street cover

Materials:

Body	Ductile Iron EN 1563 EN-GJS-500/7
Bonnet	Ductile Iron EN 1563 EN-GJS-500/7
Gland flange	Ductile Iron EN 1563 EN-GJS-500/7
Wedge	Ductile Iron EN 1563 EN-GJS-500/7
Wedge nut	Aluminium bronze EN 1982 CC331G (AB1)
Stem	Stainless steel 420s37 / A276-420
Face/seat ring	Gunmetal EN 1982 CC491K (LG2)
Bushing	Nylon
Stem collar	Brass BS 2872 CZ132
O-ring	EPDM
Gasket	EPDM
Fasteners	Zinc plated mild steel (FZV)
Coating	Internal and external blue fusion bonded epoxy (250 microns)WRAS



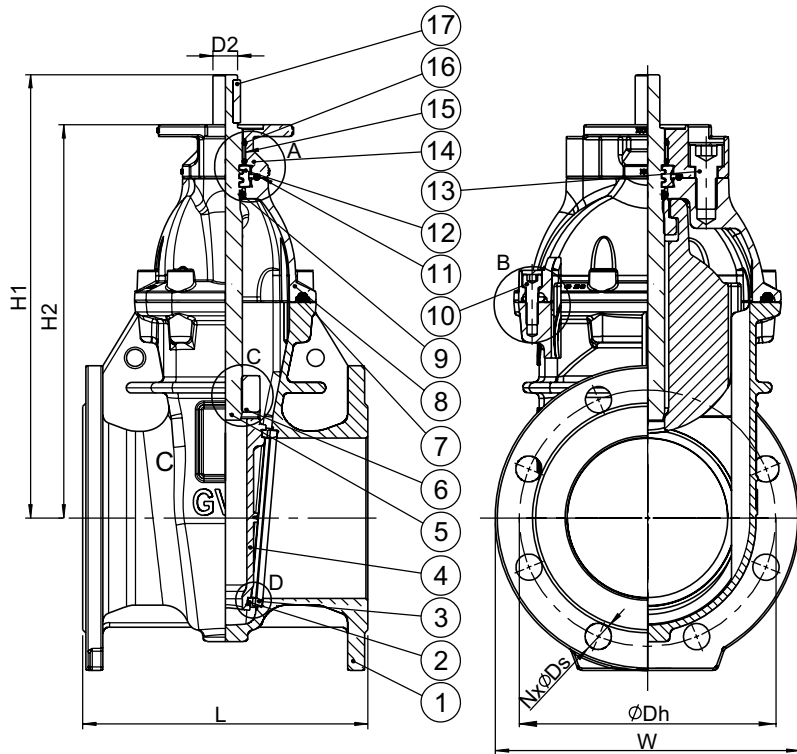

A. Stem sealing

Stem sealing exchangeable under pressure with three independent stem seals:

- A polyamid bearing with 2 EPDM O-rings ensures low friction
- An O-ring protects the stem collar and prevents leakage when exchanging stem seals under pressure.

B. Body/bonnet connection

The unique assembly of the valve body and bonnet ensures a durable tightness:

- A round rubber bonnet gasket fits into a recess in the valve bonnet preventing it from being blown out by pressure surges.
- The bonnet bolts are countersunk in the valve bonnet, encircled by the bonnet gasket and sealed with hot melt. Thus there is no risk of corrosion as the bolts are not exposed to the medium or soil.

C. Wedge nut

The wedge nut is made of bronze with lubricating abilities providing optimum compatibility with the stem.

D. Wedge

The wedge is made from ductile iron with gunmetal face rings which are machined to a fine surface finish to ensure optimum contact seal with body seat rings. The wedge face rings are accurately machined and firmly secured to the wedge. The guides in the wedge ensure uniform closure regardless of high pressures. The wedge has a large through bore housing for the stem that ensures no stagnant water or impurities can collect. The wedge is fully protected by a coating of fusion bonded epoxy.

Component list

1. Body	10. Bolt
2. Face ring	11. O-ring
3. Seat ring	12. Thrust collar
4. Wedge	13. Bolt
5. Stem	14. ISO flange
6. Wedge nut	15. Bushing
7. Bonnet gasket	16. O-ring
8. Bonnet	17. Key
9. O-ring	

Reference nos. and dimensions

AVK ref. nos.	DN mm	PN drilling	L mm	H1 mm	H2 mm	D2 mm	W mm	Dh mm	Ds mm	Number of bolts	ISO flange	Theoretical weight kg
37-050-51-010001	50	16	178	259	212	23	165	125	19	4	F10	17
37-080-51-010001	80	16	203	304	257	23	200	160	19	8	F10	21
37-100-51-010001	100	16	229	335	289	23	220	180	19	8	F10	26
37-150-51-010001	150	16	267	415	368	23	285	240	23	8	F10	43
37-200-51-010001	200	16	292	517	470	23	340	295	23	12	F10/14	76
37-250-51-010001	250	16	330	588	541	23	405	355	28	12	F10/14	107
37-300-51-010001	300	16	356	669	622	23	460	410	28	12	F10/14	164