

# Explosion proof type differential pressure switch

## Model: P970

Spec. sheet no. PD09-10

### Service intended

P970 diaphragm type differential pressure switch can be used in a variety of process lines. Internal micro switch is operated by pressure of various fluids, such as atmospheric pressure and water pressure. The pressure sensing part is a force balanced and piston actuated assembly.



### Working temperature

Ambient : -20 ~ 65°C

Fluid : Max. 100°C



## Standard features

### Pressure connection

Stainless steel (316SS)  
316L SS, Monel and Hastelloy-C

### Element

Stainless steel (316L SS)  
Monel, Hastelloy-C and Viton

### Case and cover

ALDC 12.1  
Silver gray painted aluminium

### Adjustable range

1 kPa ~ 15 MPa

### Repeatability

±1.0% of adjustable range

### Contact

Micro contact type  
One SPDT (Model : P970-1B3)  
Two SPDT (Model : P970-2B3)(Only single setpoint)  
One DPDT (Model : P970-2B3)

### Conduit connection

¾" NPF (F)

### Process connection

¼" NPT (F)

### Contact rating

AC 125 V / 250 V, 15 A  
DC 125 V, 0.5 A for resistance load  
DC 125 V, 0.05 A for inductive load

### Approval by standards

Ex d IIC T6 (KGS)  
II 2G (LCIE 06 ATEX 6073X)  
IECEX KGS-04-0001  
Ex d IIC T6 (Tamb= -20 ~ + 60°C)

**WISE**<sup>®</sup>

**1. Base model****P970** Explosion proof type differential pressure switch**2. Switch form**

- 1 One SPDT
- 2 Two SPDT (Only available with single setpoint)

**3. Unused character****B3** None**4. Process connection****C** ¼"**5. Connection type****D** NPT (F)**6. Unit**

- H** bar
- I** MPa
- J** kPa
- S** mbar

**7. Range****XXX** Refer to pressure unit and range table**8. Pressure connection / Element material**

- 3** 316SS / 316L SS
- V** 316SS / Viton
- L** 316SS / Hastelloy-C
- K** 316SS / Monel
- Z** Monel / Monel
- H** Hastelloy-C / Hastelloy-C

**9. Options**

- 0** None
- 1** 3 way / 5 way manifold valve

1	2	3	4	5	6	7	8	9
<b>P970</b>	<b>1</b>	<b>B3</b>	<b>C</b>	<b>D</b>	<b>H</b>	<b>XXX</b>	<b>3</b>	<b>0</b>

Sample  
ordering code

## P970 : Type of mounting

① 100 mmH<sub>2</sub>O ~ 1000 mmH<sub>2</sub>O

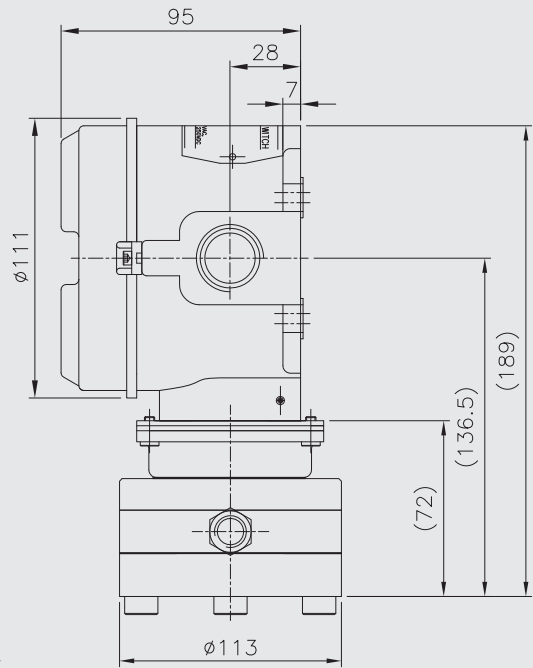
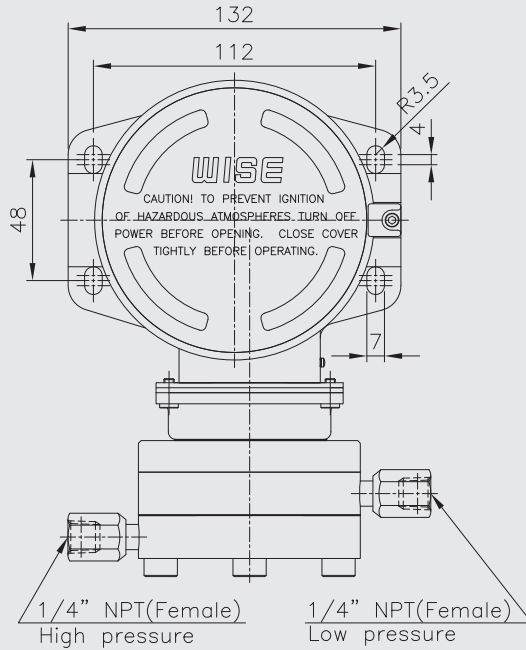

② 10 ~ 1500 kPa

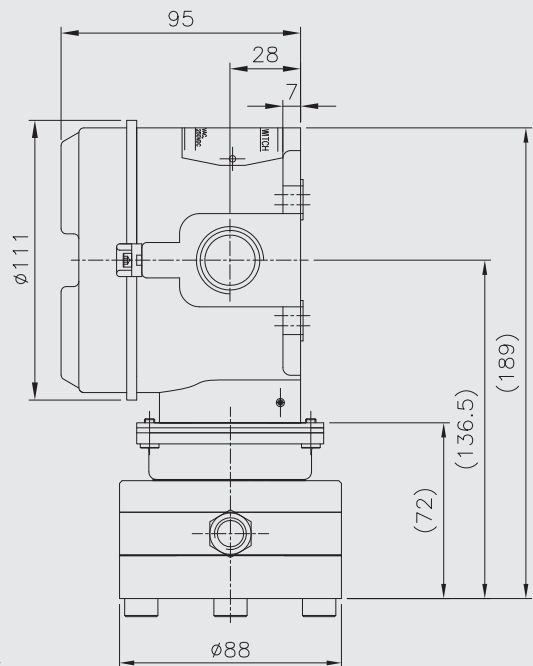
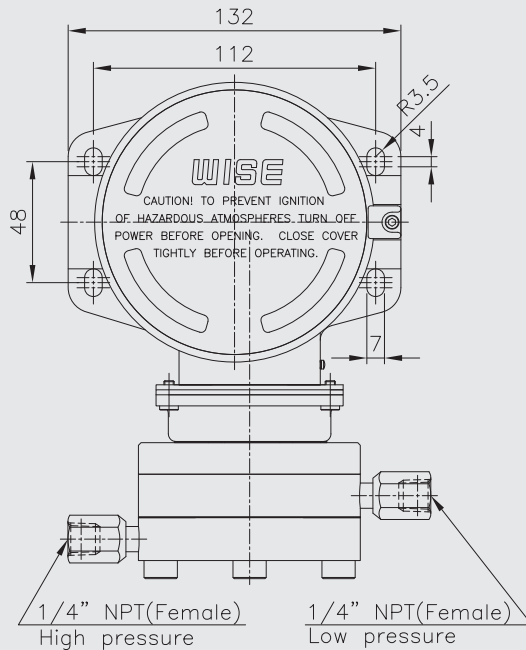

### Pressure switch

A bi-stable electro mechanical device than actuates/deactuates one or more electrical switching element at a predetermined discrete pressure upon rising or falling.

### Adjustable range

The span of pressure between upper and lower limits within which the pressure switch can be adjusted to actuate/deactuate. It is expressed for increasing pressure.

### Setpoint

That discrete pressure at which the pressure switch is adjusted to actuate/deactuate on rising or falling pressure. It must fall with the adjustable range and be called out as increasing.

### Dead band

The difference in pressure between the increasing set point and the decreasing setpoint.

### Proof pressure (Pmax)

The maximum input pressure that can be continuously applied to the pressure switch without causing permanent change of setpoint, leakage or material failure.

### Burst pressure

The maximum input pressure that can be continuously applied to the pressure switch without causing leakage or catastrophic material failure. Permanent change of set point may occur, or the device may be rendered inoperative.

### Repeatability

The ability of a pressure switch to successively operate at a set point that is approached from a starting point in the same direction and returns to the starting point over three consecutive cycles to establish a pressure profile.

The closeness of the measures set point values is normally expressed as a percentage of full scale (maximum adjustable range pressure).

## Pressure range table

Code	Adjustable setting range		
	H : bar	I : MPa	J : kPa
994	0.1 ~ 0.15		1 ~ 15
907	0.15 ~ 0.25		15 ~ 25
909	0.25 ~ 0.35		25 ~ 35
910	0.35 ~ 0.5		35 ~ 50
922	0.5 ~ 2	0.05 ~ 0.2	
905	2 ~ 4	0.2 ~ 0.4	
924	4 ~ 7	0.4 ~ 0.7	
917	7 ~ 15	0.7 ~ 1.5	

Code	Resistance load		Inductive load	
	NC	NO	NC	NO
125 V AC	15 (10)		15 (10)	
250 V AC	15 (10)		15 (10)	
480 V AC	10		10	
8 V DC	15		15	
14 V DC	15		10	
30 V DC	2		1	
125 V DC	0.4		0.03	
250 V DC	0.2		0.02	

### SPDT switching element

Single-pole, double throw (SPDT) has three connection : C-common, NO-normally open and NC-normally closed, which allows the switching element to be electrically to the circuit NO or NC state.

### DPDT switching element

Double-pole, double throw (DPDT) is two SPDT switching elements operated by a common lever assembly so simultaneous actuation / deactuation occurs at both the increasing and the decreasing set point. Two independent electrical circuits can be switched, i.e. one AC and one DC.

#### P970 1B3 type

When the input pressure reach the upper or lower limit set point.  
The circuit is closed and opened.

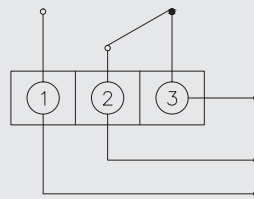

①:NO ②:COM ③:NC

#### P970 2B3 type

When the input pressure reach the upper or lower limit set point.  
Two circuit are simultaneously closed and opened.

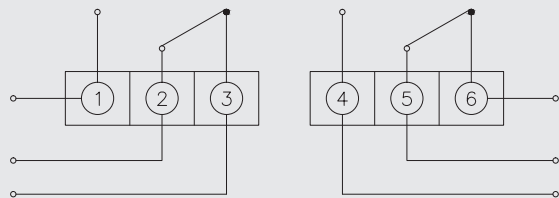

①,④:NO ②,⑤:COM ③,⑥:NC

NO : Normal open  
NC : Normal close

Blank memo area for writing.