

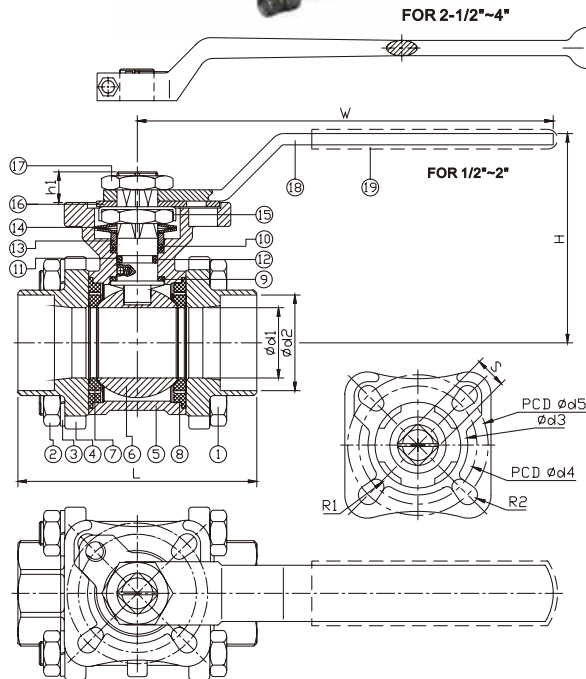

FEATURES



- Full port, 1/2"~4" (DN15~DN100)
- W.P. : 1000 WOG (PN63)
- W.T. : -20°C~200°C (-4°F~392°F)
- Investment casting
- Blow-out proof stem
- Live-loading design
- Anti-static device
- Locking device
- ISO 5211 direct mounting pad
- Length conform to DIN 3202/4-M3-2011ND-M3 (option)
- ISO 15848 fugitive emission approved (option)
- Automation accessories (option)
- Socket weld ends conform to ANSI B16.11 & DIN 3239 part2



ITEM	PARTS	MATERIAL
1	BOLT	AISI 304
2	NUT	
3	SPRING WASHER	
4	CAP	ASTM A351-CF8M
5	BODY	
6	BALL	PTFE / RTFE
7	SEAT	
8	SEAL	PTFE
9	THRUST WASHER	
10	PACKING	VITON
11	O-RING	
12	STEM	ASTM A276-316
13	GLAND RING	AISI 304
14	BELLEVILLE WASHER	AISI 301
15	LOCKING WASHER	AISI 304
16	LOCKING DEVICE	
17	STEM NUT	STAINLESS STEEL
18	HANDLE	
19	HANDLE SLEEVE	PVC

DN	d1	d2	L	H	W	S	h1	d3	d4	d5	R1	R2	Torque (N·M)
15	15	22	65	60	120	9	8.5	31	36	42	2.75	2.75	7.5
20	20	27.5	75	64	120	9	8.5	31	36	42	2.75	2.75	11
25	25	34	85	74	148	11	11	35.5	42	50	2.75	3.5	14
32	32	43	101	79	148	11	11	35.5	42	50	2.75	3.5	21
40	38	49	112	95	178	14	13.5	56	50	70	3.5	4.5	27
50	50	61	130	103	178	14	13.5	56	50	70	3.5	4.5	50
65	63	74	162	123	325	17	20.5	76	70	102	4.5	5.5	85
80	76	90	188	131.5	325	17	20.5	76	70	102	4.5	5.5	97
100	96	115.5	224	165.5	325	22	22.5	100	102	125	5.5	6.5	150

NPS	d1	d2	L	H	W	S	h1	d3	d4	d5	R1	R2	Torque (in·lb)
1/2"	0.59	0.87	2.56	2.36	4.72	0.35	0.33	1.22	1.42	1.65	0.11	0.11	66.4
3/4"	0.79	1.08	2.95	2.52	4.72	0.35	0.33	1.22	1.42	1.65	0.11	0.11	97.4
1"	0.98	1.34	3.35	2.91	5.83	0.43	0.43	1.4	1.65	1.97	0.11	0.14	123.9
1-1/4"	1.26	1.69	3.98	3.11	5.83	0.43	0.43	1.4	1.65	1.97	0.11	0.14	185.9
1-1/2"	1.5	1.93	4.41	3.74	7.01	0.55	0.53	2.2	1.97	2.76	0.14	0.18	239
2"	1.97	2.4	5.12	4.06	7.01	0.55	0.53	2.2	1.97	2.76	0.14	0.18	442.5
2-1/2"	2.48	2.91	6.38	4.84	12.8	0.67	0.81	2.99	2.76	4.02	0.18	0.22	752.3
3"	2.99	3.54	7.4	5.18	12.8	0.67	0.81	2.99	2.76	4.02	0.18	0.22	858.5
4"	3.78	4.55	8.82	6.52	12.8	0.87	0.89	3.94	4.02	4.92	0.22	0.26	1327.6

unit:mm

unit:in

