

# Fisher® A11 High-Performance Butterfly Valve

The Fisher A11 High-Performance Butterfly Valve maintains tight shutoff, and can be specified for a wide range of pressure and temperature conditions, including cryogenic applications.

The A11 valve is available in either a wafer or a single-flange design (single-flange only for CL600, 900, and 1500). A square or keyed shaft can combine with a variety of handlevers, handwheels, or pneumatic piston diaphragm actuators. A splined shaft can combine with a variety of spring-and-diaphragm or pneumatic piston actuators. These combinations help make the A11 valve a reliable, high-performance butterfly valve for both throttling and on-off applications in the process industries.

The A11 valve can be supplied with one of several dynamic seals (figure 1) that can be used in a variety of demanding applications. With the appropriate seal selection and materials of construction, the pressure-assisted seal helps provide excellent shutoff against the full ASME class pressure range for the A11 valve.

## Features

- **Shaft Versatility**— This valve will meet your actuator needs with a choice of square, keyed, or splined shaft connections.
- **Excellent Shutoff Integrity**—The pressure-assisted seal design provides tight shutoff and permits the use of smaller, less expensive actuators in applications requiring full ASME B16.34 shutoff capabilities.



W9570-1

- **Excellent Emissions Capabilities**— The optional ENVIRO-SEAL™ packing systems are designed with very smooth shaft surfaces and live-loading to provide improved sealing, guiding, and loading force transmission. The seal of the ENVIRO-SEAL system can control emissions to below 100 ppm (parts per million).
- **Sour Service Capability**— Trim and bolting materials are available for applications involving sour liquids and gases. These constructions comply with NACE MR0175-2002, MR0103, and MR0175 / ISO 15156.
- **High-Temperature/Cryogenic Capabilities**— Optional valve constructions allow this valve to meet both high-temperature and cryogenic applications (see table 7 for cryogenic and high-temperature actuator configurations).
- **Easy Installation**—The valve body self-centers on the line flange bolts as a fast, accurate means of centering the valve in the pipeline.



## Features (continued)

- **Reliable Flange Gasketing Surface**—Seal retainer screws are located so there is no interference with the sealing function of either flat sheet or spiral wound line flange gaskets.
- **True Bidirectional Shutoff Performance**—A feature of the valve design is that the torque necessary to open and close the valve is the same regardless of the direction in which the differential pressure is applied.
- **Ease of Maintenance**—Interchangeability of all parts, including shafts and disks, simplifies service and reduces maintenance costs.

## Standard Seal Configurations

- **Standard Soft Seal (PTFE CL150 and 300, and ETFE CL600, 900, and 1500)**—A resilient dynamic seal with an elastomeric back-up ring for low to moderate temperature applications.

- **Metal Seal**—This stainless steel seal is available for severe service and high-temperature applications to 704°C (1300°F) for NACE applications and 816°C (1500°F) for other applications.
- **NOVEX Seal**—The NOVEX stainless steel seal is available for severe service, Cryogenic, and high-temperature applications to 816°C (1500°F). Available for CL150/150, 150, and 300, up to NPS 36 only.
- **Phoenix III Seal**—This three-component, metal-and-polymeric seal is available for severe service with low to moderate temperature applications.
- **High-Pressure Seal (CL600, 900, and 1500)**—This robust, stainless steel seal is available for severe service, cryogenic, and high-temperature applications to 704°C (1300°F), for NACE, and for other applications to 816°C (1500°F).
- **Cryo-Tight Cryogenic Seal**—This resilient dynamic seal is available with or without an aluminum back-up ring for low temperature applications.

---

### Table of Contents

Features .....	1
Standard Seal Configurations .....	2
Specifications .....	3

Installation .....	4
Dimensions and Weights .....	9
Pressure Drops .....	16

**Specifications**

**Available Configurations and Sizes**

■ Flangeless (wafer) or ■ Single-flange (lugged)

*Available Sizes and Shaft Styles*

PRESSURE RATING	VALVE SIZE, NPS		
	Keyed	Square	Splined
CL150/150 <sup>(1)</sup>	30 to 72	---	---
CL150	30 to 72	---	---
CL300	30 to 72	---	---
CL600	14 to 48 (standard), 3 to 12 (optional)	3 to 12 (optional)	3 to 12 (standard) 14 to 24 (optional)
CL900	12 to 24 (standard), 6 to 10 (optional)	6 to 10 (standard)	Consult your <a href="#">Emerson Process Management sales office</a>
CL1500	10 to 20 (standard)	---	
CL2500	Consult your Emerson Process Management Sales Office		

1. Refers to a valve construction consisting of a CL150 body and trim suitable for a shutoff pressure drop of 150 psid.

**End Connection Style**

Flangeless or single flange style designed to fit between raised-face mating flanges of appropriate class pressure rating

ASME B16.5

NPS 3 through 24: CL600

NPS 6 through 24: CL900

NPS 10 through 20: CL1500

ASME B16.47 Class A and MSS-SP-44

NPS 30 through 48: CL150, 300, and 600

NPS 30 through 36: CL900

Consult your [Emerson Process Management sales office](#) for valves compatible with API 605 and ASME B16.47 Class B flanges



**Maximum Inlet Pressure<sup>(1)</sup>**

Valve Body: Consistent with CL150, 300, 600, 900, and 1500 pressure/temperature ratings per ASME B16.34, see table 17

Seal: see figure 1

**Materials of Construction**

See table 1

Disk Hard Surfacing: All CL600, 900, and 1500 disk edges must be coated, regardless of the seal type. Metal, NOVEX, Phoenix III and cryogenic seals require the disk to be coated, regardless of the valve class.

**Maximum Temperature Capabilities<sup>(1)</sup>**

See table 1

High-Temperature and Cryogenic Applications: See table 7 for available valve and actuator combinations

**Shutoff Classification per ANSI/FCI 70-2 and IEC 60534-4**

Standard Soft Seal: Bubble-tight shutoff (exceeds Class VI)

Metal Seal: 20% of Class IV (reverse direction only)

NOVEX Seal: Standard Class V (Class VI optional, reverse direction only)

Phoenix III Seal: Bubble-tight (reverse direction only), Class VI (forward direction only)

High Pressure Seal: Standard Class V (Class VI optional, reverse direction only)

Cryogenic Seal (Reverse direction only): NOVEX: Class VI

CTFE: 10% of Class IV

CTFE with Aluminum Backup Ring: Class VI

**Flow Characteristic**

Modified equal percentage

**Flow Coefficients**

See Fisher Catalog 12

**Noise Levels**

See Fisher Catalog 12 for sound pressure level prediction

**Available Actuators**

Handlever; handwheel; or pneumatic piston, spring return, double-acting, spring and diaphragm

**Disk Rotation**

Clockwise (CW) to close

**Valve Dimensions and Approximate Weights**

See figures 3, 4, 5, 6 and 7

For general packing guidelines, see [Bulletin 59.3:042 Packing Selection Guidelines for Rotary Valves, D102093X012](#)

For information on ENVIRO-SEAL packing system see [Bulletin 59.3:041 ENVIRO-SEAL Packing Systems for Rotary Valves, D101638X012](#)

1. The pressure/temperature limits in this bulletin, and any applicable code or standard limitation, should not be exceeded.

Figure 1. Available Seal Configurations

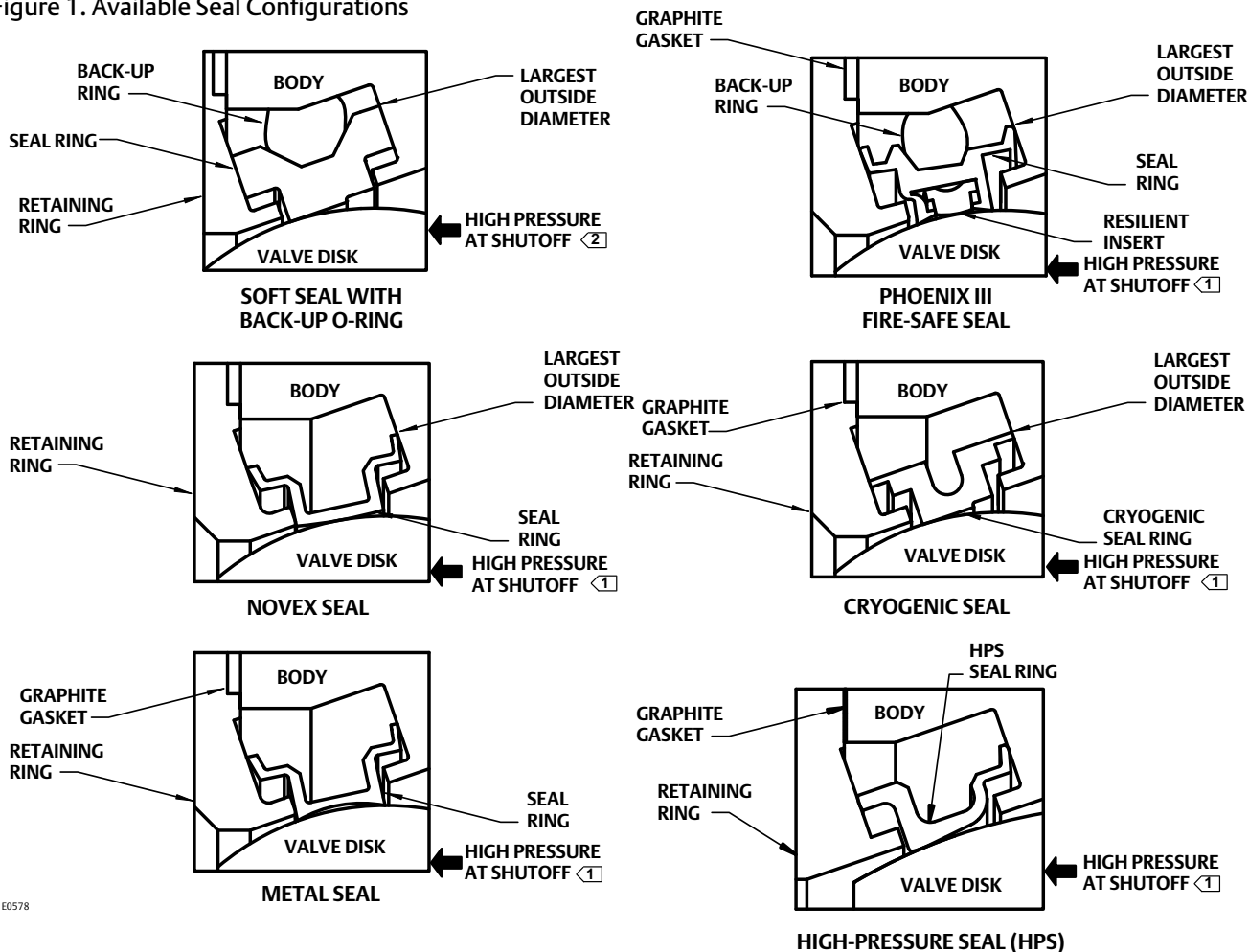

E0578

Notes:

- ① This unidirectional seal must be installed so that the retaining ring is downstream from the high pressure side of the valve at shutoff, as shown.
- ② For this bidirectional seal, the "preferred" valve orientation places the retaining ring downstream from the high pressure side of the valve at shutoff.

## Installation

Preferred valve orientation for the A11 valve is reverse flow direction. Reverse flow direction is into the side of the valve body opposite the retaining ring or into the shaft side of the disk.

For erosive and many severe service applications, valves with bidirectional seals can and should be installed with the shaft horizontal and in the forward flow direction to prevent direct impingement of the process media on the seal, and to minimize the exposure of the shaft bearings to the process media.

The standard soft seal and the Phoenix III seal both offer bidirectional shutoff. Valves using either metal, NOVEX, or cryogenic seals are unidirectional and must be installed in the reverse flow orientation.

For assistance in selecting the appropriate combination of actuator action and open valve position, consult your [Emerson Process Management sales office](#).

Dimensions and weights for wafer-style and single-flange valves are shown in figures 3, 4, 5, 6, and 7.

**Table 1. Material Temperature Ranges**

PART NAME	MATERIAL	TEMP °C	TEMP °F	
Valve Body <sup>(1)</sup>	WCC Steel, SA-516-70 or SA-105	-29 to 427	-20 to 800	
	CF8M, CF8, CF3M, CF3	-254 to 538	-425 to 1000	
	CF8M, CF8C, CF8 <sup>(2)</sup> FMS 20B16 a Fisher material standard (0.04% min carbon)	over 538 to 816	over 1000 to 1500	
	LCC	-45 to 343	-50 to 650	
	C12A	-29 to 649	-20 to 1200	
	WC9	-29 to 593	-20 to 1100	
Disk <sup>(5)</sup>	CG8M, CG3M, CF8C	-198 to 538	-325 to 1000	
	WCC Steel	-29 to 427	-20 to 800	
	CF8M, CF8, CF3M, CF3	-254 to 538	-425 to 1000	
	CF8M, CF8C, CF8 <sup>(2)</sup> FMS 20B16 a Fisher material standard (0.04% min carbon)	over 538 to 816	over 1000 to 1500	
Disk Seating Surface Coating	CB7Cu-1	-29 to 427	-20 to 800	
	CG8M, CG3M, CF8C	-198 to 538	-325 to 1000	
	Chrome Plating	-254 to 427	-425 to 800	
	Chromium Coat per FFS 2E1	-254 to 593	-425 to 1100	
	Electroless Nickel Coating (ENC)	-254 to 343	-425 to 650	
Shaft	Chromium Carbide Coating	-254 to 816	-425 to 1500	
	CoCr-A (Alloy 6) <sup>(4)</sup>			
	S17400 (H1025)	-73 to 427	-100 to 800	
	S17400 (H1150M)	-196 to 427	-320 to 800	
	N05500 <sup>(4)</sup>	-254 to 482	-425 to 900	
	N07718	-254 to 704	-425 to 1300	
Bearings <sup>(3)</sup>	S20910 <sup>(4)</sup>	-196 to 593	-320 to 1100	
	N07750 <sup>(4)</sup>	over 593 to 816	over 1100 to 1500	
	PEEK	-73 to 260	-100 to 500	
	PTFE Composition	-254 to 163	-425 to 325	
	S31600 (316 SST Nitrided)	-254 to 816	-425 to 1500	
R30006 (Alloy 6) <sup>(4)</sup>				
Seal Ring	Bronze <sup>(4)</sup>	-254 to 302	-425 to 575	
	PTFE Lined N04400 <sup>(4)</sup>	-254 to 232	-425 to 450	
	Soft - PTFE	-62 to 232	-80 to 450	
	Soft - ETFE	-54 to 149	-65 to 300	
Backup Ring	Metal - All	See table 2		
	HPS - S20910 <sup>(4)</sup>	-254 to 649	-425 to 1200	
	<b>Used with Soft Seal</b>			
	Fluorocarbon	-29 to 204	-20 to 400	
	EPR	-54 to 182	-65 to 360	
	Nitrile <sup>(4)</sup>	-29 to 93	-20 to 200	
	Chloroprene <sup>(4)</sup>	-43 to 149	-45 to 300	
	<b>Used with Phoenix III Seal</b>			
	Fluorocarbon	-40 to 232	-40 to 450	
	EPR	-62 to 204	-80 to 400	
	Nitrile <sup>(4)</sup>	-40 to 149	-40 to 300	
	Chloroprene <sup>(4)</sup>	-54 to 149	-65 to 300	
<b>Used with Cryogenic Seal</b>				
Aluminum <sup>(4)</sup>	-254 to 149	-425 to 300		
Packing	PTFE V-Ring	-254 to 232	-425 to 450	
	PTFE ENVIRO-SEAL	-254 to 232	-425 to 450	
	Square Ring Graphite for Oxidizing Service	-254 to 538	-425 to 1000	
	Square Ring Graphite for Non-oxidizing Service	-254 to 816	-425 to 1500	
	Graphite ENVIRO-SEAL	-198 to 315	-325 to 600	

1. Special gasket retainer bolts are required for over 538°C (1000° F).  
2. Special retaining ring screws for single flange valves over 538°C (1000° F).  
3. Special thrust bearings are required for high temperature applications over 343°C (650° F) (with 6 and 12 inch extensions). Constructions with carbon steel valves and SST disks may require special thrust bearings at temperatures greater than 343°C (650° F).  
4. Special option; contact your [Emerson Process Management sales office](#).  
5. For valves NPS 30 and larger at temperatures over 254°C (450° F), the disk material should be the same as the valve body material.

**Table 2. Temperature Limits for Metal Seal**

SEAL TYPE	PRESSURE RATING	SEAL MATERIAL	MAXIMUM TEMPERATURE LIMITS		BACKUP RING
			°C	°F	
Metal	CL150/150, and 150 <sup>(2)</sup>	S31600 w/ CF8M disk	538	1000	No
		S31600 w/ WCC disk <sup>(2)</sup>	232	450	
	300	S31600 w/ CF8M disk	816	1500	No
		S31600 w/ WCC disk <sup>(2)</sup>	232	450	
600 <sup>(1, 2)</sup>	S20910 NACE w/ CF8M disk S20910 w/ WCC disk	649	1200	No	
		232	450		
		S17400 H1150M w/ CF8M disk	232	450	No
		S17400 H1150M w/ WCC disk	427	800	

1. When used with CF8M disks, S20910 is the preferred seal material. When used with WCC disks, S17400 H1150M is the preferred material.  
2. For valves with WCC disks at temperatures over 254°C (450°F), contact your [Emerson Process Management sales office](#) for seal material selection.

**Table 3. Trim Descriptions - CL600**

Trim Type	Trim Number	Temperature Range	Disk Material	Disk Edge Coating	Seal Type	Seal Material	Shaft	Bearings	Packing
Standard	500 <sup>(1)</sup>	-29 to 149°C -20 to 300°F	CF8M	Chrome Plated	Soft	ETFE	S17400 H1025	PEEK	PTFE
	502	-46 to 232°C -50 to 450°F	CF8M	Chrome Plated	Metal	S20910	S17400 H1025	PEEK	PTFE
	504	-40 to 149°C -40 to 300°F	CF8M	Chrome Plated	Phoenix III	S31600/ETFE	S17400 H1025	PEEK	PTFE
	506 <sup>(2)</sup>	-46 to 427°C -50 to 800°F	CF8M	Chromium Coat per FFS 2E1	Metal	S20910	S17400 H1025	316 SST Nitrided	Graphite
High-Temperature	514H <sup>(3)</sup>	-46 to 427°C -50 to 800°F	CF8M	Chromium Coat per FFS 2E1	Metal	S20910	S17400 H1025	316 SST Nitrided	Graphite
	516H <sup>(4)</sup>	-46 to 538°C -50 to 1000°F	CF8M	Chromium Coat per FFS 2E1	Metal	S21800	N07718	316 SST Nitrided	Graphite
Cryogenic	517C <sup>(5)</sup>	-196 to 163°C -320 to 325°F	CF8M	Chrome Plated	HPS	S20910 Nitrided	S17400 H1150M	PTFE Composition	PTFE

1. Trim 500 is furnished as standard trim in all CL600 A11 valves.  
2. If operating temperature is above 343°C (650°F), see table 7 for available actuator configurations.  
3. Trim includes 6-inch shaft extension.  
4. Trim includes 12-inch shaft extension.  
5. Trim includes Cryogenic shaft extension, see table 6 for extension length.

**Table 4. Trim Descriptions - CL900 and CL1500**

Trim Type	Trim Number	Temperature Range	Disk Material	Disk Edge Coating	Seal Type	Seal Material	Shaft	Bearings	Packing <sup>(5)</sup>
Standard	500 <sup>(1)</sup>	-29 to 149°C -20 to 300°F	CB7Cu-1	Chrome Plated	Soft	ETFE	S17400 H1025	PEEK	PTFE
	502	-46 to 232°C -50 to 450°F	CB7Cu-1	Chrome Plated	HPS	S20910 Nitrided	S17400 H1025	PEEK	PTFE
	504	-40 to 149°C -40 to 300°F	CB7Cu-1	Chrome Plated	Phoenix III	S31600/ETFE	S17400 H1025	PEEK	PTFE
	506 <sup>(2)</sup>	-46 to 427°C -50 to 800°F	CB7Cu-1	Chromium Coat per FFS 2E1	HPS	S20910 Nitrided	S17400 H1025	316 SST Nitrided	Graphite
High-Temperature	514H <sup>(3)</sup>	-46 to 427°C -50 to 800°F	CB7Cu-1	Chromium Coat per FFS 2E1	HPS	S20910 Nitrided	S17400 H1025	316 SST Nitrided	Graphite
	516H <sup>(4)</sup>	-46 to 538°C -50 to 1000°F	CF8M	Chromium Coat per FFS 2E1	HPS	S21800 Nitrided	N07718	316 SST Nitrided	Graphite

1. Trim 500 is furnished as standard trim in all CL1500 A11 valves.  
2. If operating temperature is above 343°C (650°F), see table 7 for available actuator configurations.  
3. Trim includes 6-inch shaft extension.  
4. Trim includes 12-inch shaft extension.  
5. Consult [Bulletin 59.3-042 Packing Selection Guidelines for Rotary Valves, D102093X012](#) for packing selection guidelines regarding pressure/temperature limits.

**Table 5. Trim Descriptions - CL150/150, CL150, and CL300**

Trim Type	Trim Number	Temperature Range	Disk Material	Disk Edge Coating	Seal Type	Seal Material	Shaft	Bearings	Packing
Standard	550 <sup>(1)</sup>	-29 to 204°C -20 to 400°F	CF8M or WCC	None	Soft	PTFE	S17400 H1025	PEEK	PTFE
	552	-46 to 232°C -50 to 450°F	CF8M or WCC	Chrome Plated	NOVEX <sup>(6)</sup>	S31600	S17400 H1025	PEEK	PTFE
	554	-40 to 232°C -40 to 450°F	CF8M or WCC	Chrome Plated	Phoenix III	S31600/PTFE	S17400 H1025	PEEK	PTFE
	555	-46 to 316°C -50 to 600°F	CF8M or WCC	Chrome Plated	NOVEX <sup>(6)</sup>	S31600	S17400 H1025	316 SST Nitrided	Graphite
	556 <sup>(2)</sup>	-46 to 427°C -50 to 800°F	CF8M or WCC	Chromium Coat per FFS 2E1	NOVEX <sup>(6)</sup>	S31600	S17400 H1025	316 SST Nitrided	Graphite
High-Temperature	564H <sup>(3)</sup>	-46 to 427°C -50 to 800°F	CF8M or WCC	Chromium Coat per FFS 2E1	NOVEX <sup>(6)</sup>	S31600	S17400 H1025	316 SST Nitrided	Graphite
	566H <sup>(4)</sup>	-46 to 538°C -50 to 1000°F	CF8M	Chromium Coat per FFS 2E1	NOVEX <sup>(6)</sup>	S31600	N07718	316 SST Nitrided	Graphite
Cryogenic	567C <sup>(5)</sup>	-196 to 163°C -320 to 325°F	CF8M	Chrome Plated	NOVEX <sup>(6)</sup>	S31600	S17400 H1150M	PTFE Composition	PTFE

1. Trim 550 is furnished as standard trim in all CL150/150, 150, and 300 A11 valves.  
2. If operating temperature is above 343°C (650°F), see table 7 for available actuator configurations.  
3. Trim includes 6-inch shaft extension.  
4. Trim includes 12-inch shaft extension.  
5. Trim includes Cryogenic shaft extension, see table 6 for extension length.  
6. NPS 42 and 48 will have an S31600 metal seal ring in place of the S31600 NOVEX seal ring.

**Table 6. Cryogenic Shaft Extension Lengths<sup>(1)</sup>**

CRYOGENIC EXTENSION LENGTH, INCH FOR VALVE BODY SIZE, NPS														
3	4	6	8	10	12	14	16	18	20	24	30	36	42	48
14-3/4	17-3/4	19-1/4	26-3/4	28-1/2	33-1/2	36	36	36	36	36	36	36	36	36

1. Extension length measured from center of valve body to bottom of packing flange.

**Table 7. Valve/Actuator Combinations**

TEMPERATURE RANGE	SELECTION GUIDELINES	
	1052, 1061, or 2052 <sup>(1, 2)</sup>	Bettis <sup>TM(3)</sup> , FieldQ <sup>TM (5)</sup> , 1035 <sup>(5)</sup> , or Hytork <sup>TM XL</sup>
-254 to -196°C (-425 to -320°F)	Valve with cryogenic extension and special trim materials <sup>(4)</sup> and standard actuator	Valve with cryogenic extension and special trim materials <sup>(4)</sup> and standard actuator
-196 to -46°C (-320 to -50°F)	Valve with cryogenic extension and trim and standard actuator	Valve with cryogenic extension and trim and standard actuator
-46 to 343°C (-50 to 650°F)	Valve (select appropriate trim) and standard actuator	Valve (select appropriate trim) and standard actuator
343 to 426°C (650 to 800°F)	Mounting positions 1 and 3: Valve (select appropriate trim) and standard actuator Mounting positions 2 and 4: Valve with 6-inch extension (select trim 514H or 564H) and standard actuator - ambient temperature may dictate the need for a high-temperature diaphragm	Valve (select appropriate trim) and actuator with high-temperature O-rings option or Valve with 6-inch extension (select trim 514H) and standard actuator
426 to 538°C (800 to 1000°F)	Mounting positions 1 and 3: Valve (select appropriate trim) and standard actuator Mounting positions 2 and 4: Valve with 6-inch extension (select trim 564H or 514H with N07718 shaft) and standard actuator - ambient temperature may dictate the need for a high-temperature diaphragm	Valve (select appropriate trim) and actuator with high-temperature O-rings option or Valve with 6-inch extension (select trim 564H or 514H with N07718 shaft) and standard actuator
538 to 816°C (1000 to 1500°F)	Valve with 12-inch extension and special trim materials <sup>(4)</sup> and standard actuator	Valve with 12-inch extension and special trim materials <sup>(4)</sup> and standard actuator

1. Select splined shaft option when necessary (standard for NPS 3-12 CL600 valves).  
 2. See figure 2 for actuator mounting positions.  
 3. Select keyed shaft option when using Bettis "G" Series Actuator, NPS 6-12.  
 4. Consult your [Emerson Process Management sales office](#).  
 5. Select square shaft option when using FieldQ or 1035 actuators.

**Figure 2. Mounting Styles and Positions**

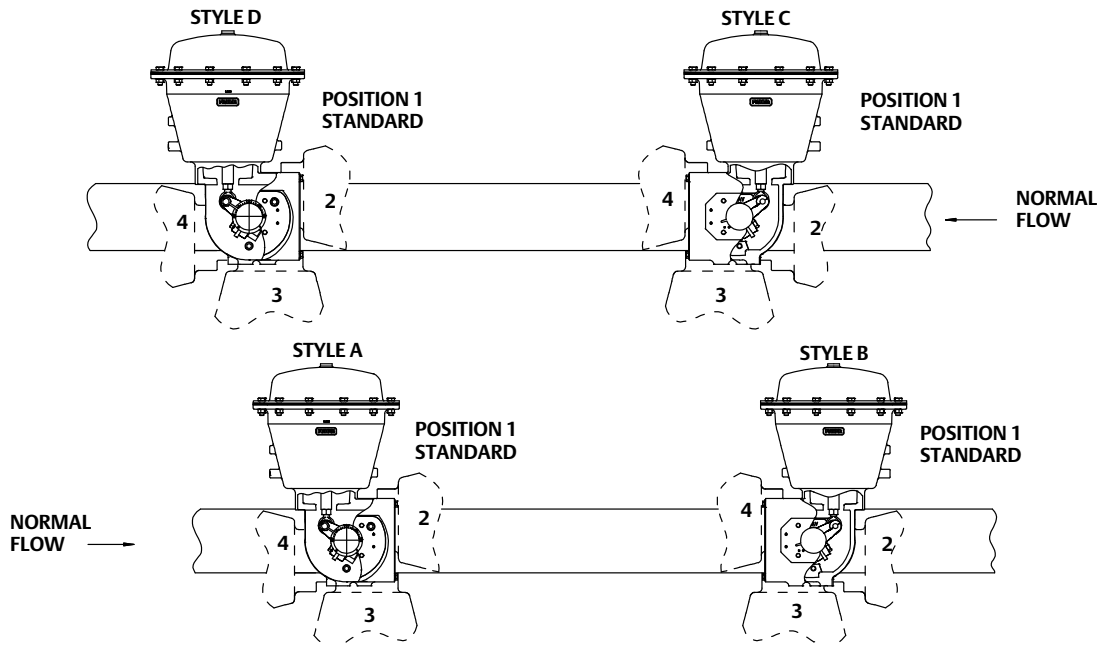

GE37285

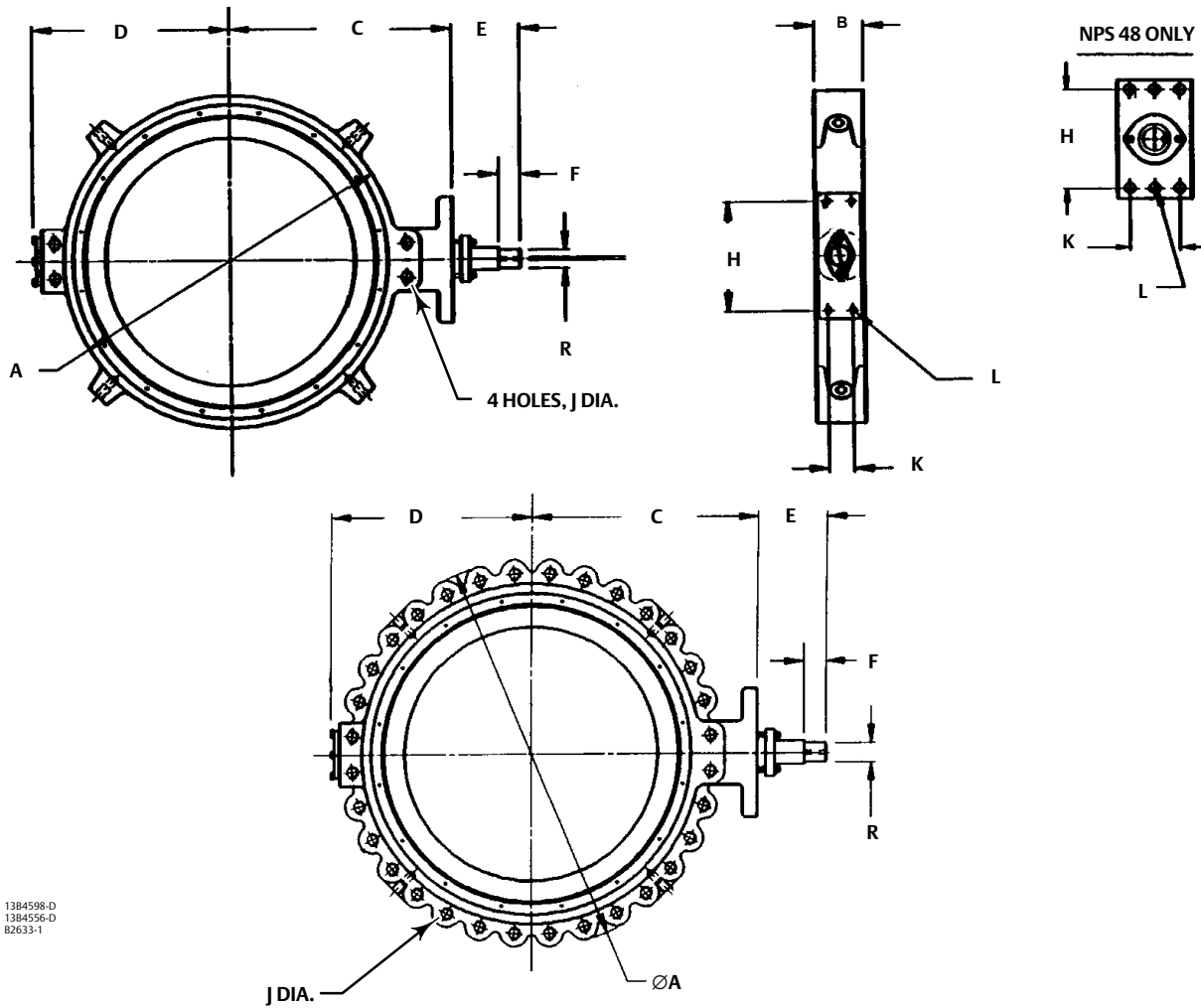

**Table 8. Dimensions and Weights Wafer and Single Flange Style CL150/150**

VALVE SIZE, NPS	A		B	C	D	E	F	H	J	K	L	M <sup>(1)</sup>	R	KEY SQ SIZE	APPROX WEIGHT
	Wafer	Single Flange													
mm															
30	864	994	121	559	516	295	95.25	337	See Thread Info Below	76.2	See Thread Info Below	744	57.2	12.7	528
36	1029	1178	149	683	613	295	95.25	337		76.2		888	57.2	12.7	806
42	1207	1356	210	762	695	314	114.3	337		76.2		1032	69.9	15.9	1302
48	1364	1524	229	889	826	314	114.3	305		152		1180	69.9	15.9	1904
Inches															
30	34.00	39.12	4.75	22.00	20.31	11.62	3.75	13.25	1-1/4-8	3.00	7/8-9	29.30	2.25	1/2	1164
36	40.50	46.38	5.88	26.88	24.12	11.62	3.75	13.25	1-1/2-8	3.00	7/8-9	34.96	2.25	1/2	1778
42	47.50	53.38	8.25	30.00	27.38	12.38	4.5	13.25	1-1/2-8	3.00	7/8-9	40.64	2.75	5/8	2871
48	53.69	60.00	9.00	35.00	32.50	12.38	4.5	12.00	1-1/2-8	6.00	1-1/4-7	46.47	2.75	5/8	4198

1. M dimension is disk chordal swing diameter.

**Figure 3. Dimensions Wafer and Single Flange Style CL150/150 (also see table 8)**



1384598-D  
1384556-D  
82633-1

Table 9. Dimensions and Weights Wafer and Single Flange Style CL150

VALVE SIZE, NPS	A		B	C	D	E	F	H	J	K	L	M <sup>(1)</sup>	R	KEY SQ SIZE	APPROX WEIGHT
	Wafer	Single Flange													
mm															
30	866.6	991	158.8	590.6	520.7	314.5	114.3	336.6	See Thread Info Below	76.2	See Thread Info Below	735.8	69.9	15.9	528
36	1031.7	1175	177.8	657.4	619.3	314.5	114.3	304.8		152.4		887.7	69.9	15.9	806
42	1050	1360	228.6	838.2	730.3	314.5	114.3	304.8		152.4		1028.2	69.9	15.9	1302
48	1371.6	1524	260.4	901.7	797.1	314.5	114.3	508.0		203.2		1110.9	69.9	15.9	1904
Inches															
30	34.12	39.00	6.25	23.25	20.50	12.38	4.5	13.25	1-1/4-8	3.00	7/8-9	28.97	2-3/4	5/8	1164
36	40.62	46.25	7.00	25.88	24.38	12.38	4.5	12.00	1-1/2-8	6.00	1-1/4-7	34.95	2-3/4	5/8	1778
42	47.50	53.56	9.00	33.00	28.75	12.38	4.5	12.00	1-1/2-8	6.00	1-1/4-7	40.48	2-3/4	5/8	2871
48	54.00	60.00	10.25	35.50	31.38	12.38	4.5	20.00	1-1/2-8	8.00	1-1/4-7	46.09	2-3/4	5/8	4198

1. M dimension is disk chordal swing diameter.

Figure 4. Dimensions Wafer and Single Flange Style CL150 (also see table 9)

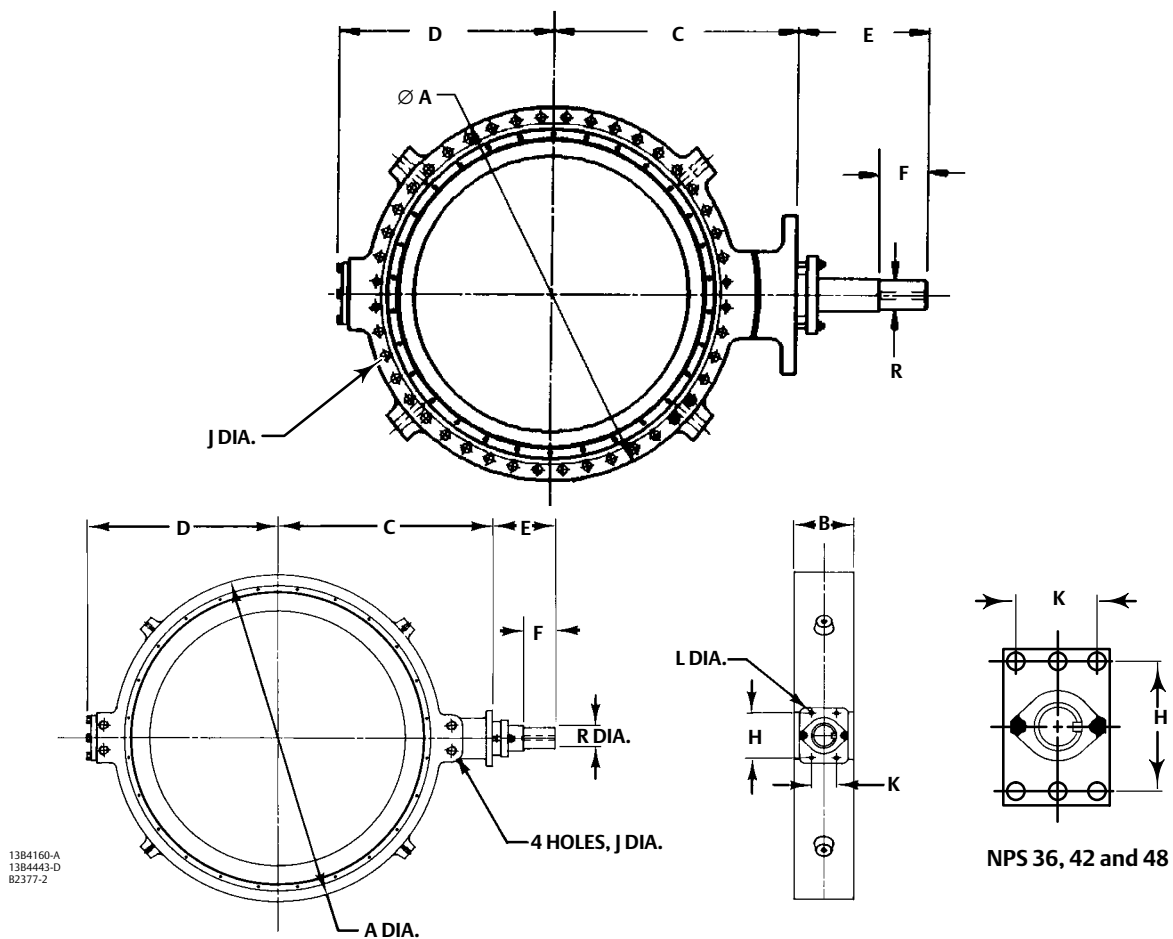

Table 10. Dimensions and Weights Wafer and Single Flange Style CL300

VALVE SIZE NPS	A		B	C	D	E	F	H	J	K	L	M <sup>(1)</sup>	R	KEY SQ SIZE	APPROX WEIGHT
	Wafer	Single Flange													
mm															
30	865	1105	241	648	576	314	114.3	508	See Thread Info Below	203	See Thread Info Below	681	70	15.9	952
36	1035	1286	273	740	675	353	152.4	432		203		838	95	22.2	1315
42	1162	1346	299	867	768	363	163.6	432		203		943	102	25.4	2263
48	1315	1484	422	934	888	497	114.3	660		330		1125	146	38.1	3056
Inches															
30	34.06	43.50	9.50	25.50	22.69	12.38	4.5	20.00	1-3/8	8.00	1-1/4	26.80	2-3/4	5/8	2100
36	40.75	50.62	10.75	29.12	26.56	13.88	6	17.00	2-8	8.00	1-1/4	32.99	3-3/4	7/8	2900
42	45.75	53.00	11.75	34.12	30.25	14.31	6.44	17.00	1-5/8	8.00	1-1/4	37.13	4	1	4989
48	51.75	58.44	16.62	36.75	34.94	19.56	4.5	26.00	1-7/8	13.00	1-1/4	44.29	5-3/4	1-1/2	6738

1. M dimension is disk chordal swing diameter.

Figure 5. Dimensions Wafer and Single Flange Style CL300 (also see table 10)

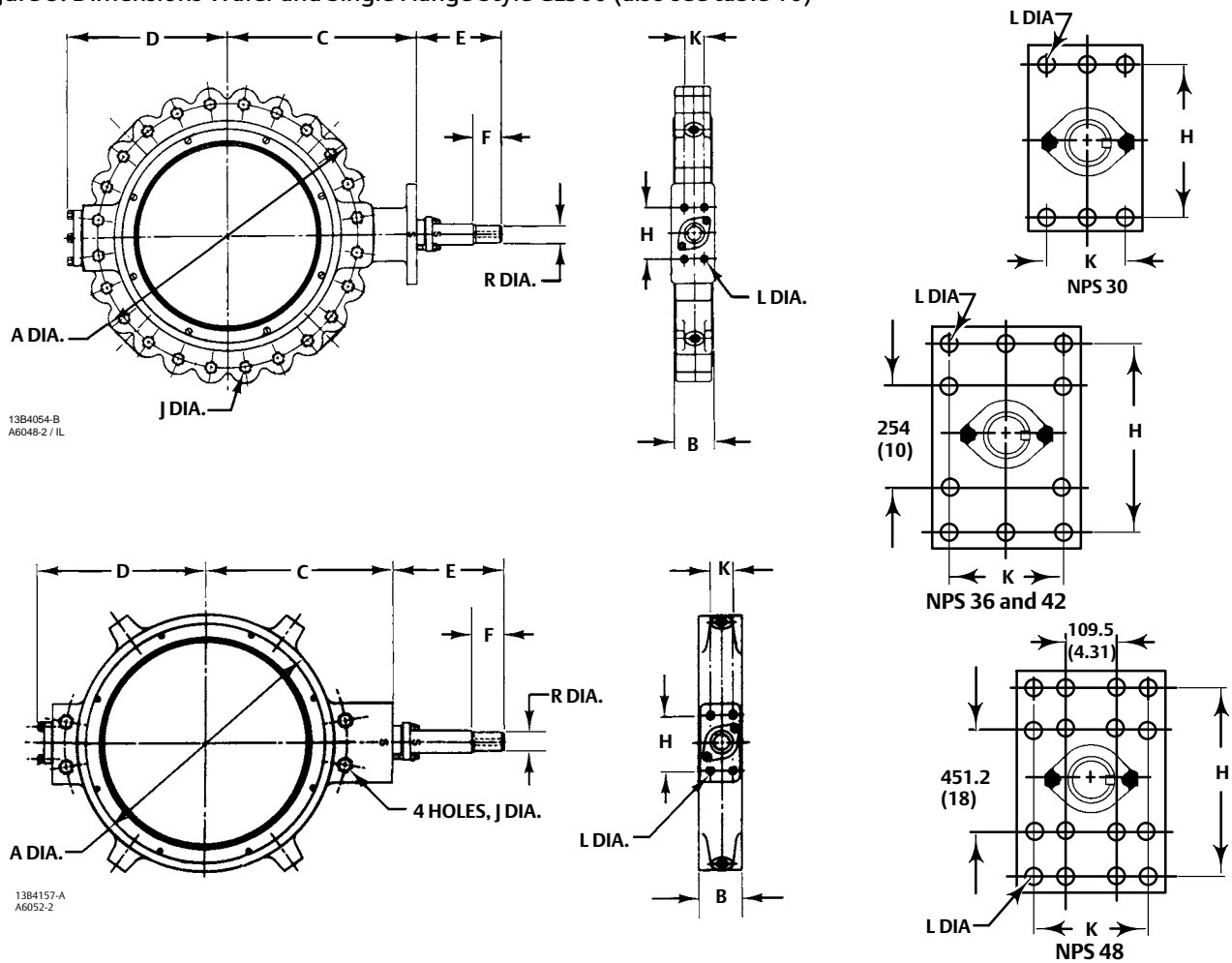

Table 11. Dimensions and Weights Single Flange Style CL600

VALVE SIZE, NPS	A	B	C	D	E			F		G Square	H	K	M(1)	R <sub>o</sub>		KEY SQ SIZE	APPROX WEIGHT
					Keyed Shaft	Splined Shaft	Sq Shaft	Keyed Shaft	Splined Shaft					Keyed	Splined		
<b>mm</b>																	<b>kg</b>
3	213	46	146	83	210	187	57	66.68	67	10.3	89	---	64	12.7	14.2 x 15.9	3.2	9
4	276	61	178	105	210	214	67	66.68	73	15.9	114	---	86	15.9	19.1	4.8	10
6	346	73	235	156	210	214	90	66.68	86	22.2	114	---	127	25.4	25.4	6.4	25
8	424	89	260	230	210	208	90	66.80	92	25.4	127	51	182	31.8	38.1	6.4	52
10	521	114	321	282	210	356	95	66.80	156	34.9	127	51	221	38.1	44.5	9.5	113
12	569	140	356	318	210	356	95	73.15	156	34.9	273	51	260	44.5	44.5	9.5	153
14	613	159	371	343	295	356	---	95.25	156	---	337	76.2	282	57.2	50.8	12.7	186
16	689	178	432	384	314	356	---	114.3	156	---	337	76.2	321	69.9	55.9	15.9	274
18	752	197	476	430	314	(2)	---	114.3	(2)	---	305	152.4	371	69.9	(2)	15.9	361
20	823	229	508	449	314	(2)	---	114.3	(2)	---	305	152.4	399	69.9	(2)	15.9	526
24	946	229	562	524	314	(2)	---	114.3	(2)	---	508	203.2	516	69.9	(2)	15.9	669
<b>Inches</b>																	<b>lbs</b>
3	8.38	1.81	5.75	3.25	8.25	7.38	2.25	2.625	2.62	13/32	3.50	---	2.52	1/2	9/16 x 5/8	1/8	20
4	10.88	2.38	7.00	4.12	8.25	8.44	2.62	2.625	2.88	5/8	4.50	---	3.40	5/8	3/4	3/16	23
6	13.62	2.88	9.25	6.12	8.25	8.44	3.56	2.625	3.38	7/8	4.50	---	4.98	1	1	1/4	54
8	16.69	3.50	10.25	9.06	8.25	8.19	3.56	2.63	3.63	1	5.00	2.00	7.17	1-1/4	1-1/2	1/4	115
10	20.50	4.50	12.62	11.12	8.25	14.00	3.75	2.63	6.13	1-3/8	5.00	2.00	8.70	1-1/2	1-3/4	3/8	249
12	22.38	5.50	14.00	12.50	8.25	14.00	3.75	2.88	6.13	1-3/8	10.75	2.00	10.22	1-3/4	1-3/4	3/8	337
14	24.12	6.25	14.62	13.50	11.63	14.00	---	3.75	6.13	---	13.25	3.00	11.09	2-1/4	2	1/2	410
16	27.12	7.00	17.00	15.12	12.38	14.00	---	4.5	6.13	---	13.25	3.00	12.63	2-3/4	2-1/2	5/8	605
18	29.62	7.75	18.75	16.94	12.38	(2)	---	4.5	(2)	---	12.00	6.00	14.62	2-3/4	(2)	5/8	796
20	32.38	9.00	20.00	17.69	12.38	(2)	---	4.5	(2)	---	12.00	6.00	15.71	2-3/4	(2)	5/8	1160
24	37.25	9.00	22.12	20.62	12.38	(2)	---	4.5	(2)	---	20.00	8.00	20.32	2-3/4	(2)	5/8	1475

1. M dimension is the disk chordal swing diameter.  
2. Consult your [Emerson Process Management sales office](#).

Table 12. Dimensions Single Flange Style CL600

VALVE SIZE, NPS	L	P
	<b>mm</b>	
3 - 24	See Thread Info Below	See Thread Info Below
VALVE SIZE, NPS	<b>Inches</b>	
3	0.53	3/4-10 8 holes
4	0.53	7/8-9 8 holes
6	0.53	1-8 12 holes
8	1/2-13	1-1/8-8 12 holes
10	3/4-10	1-1/4-8 16 holes
12	3/4-10	1-1/4-8 20 holes
14	7/8-9	1-3/8-8 20 holes
16	7/8-9	1-1/2-8 20 holes
18	1-1/4-7	1-5/8-8 20 holes
20	1-1/4-7	1-5/8-8 24 holes
24	1-1/4-7	1-7/8-8 24 holes

Figure 6. Dimensions Single Flange Style CL600 (also see table 11)

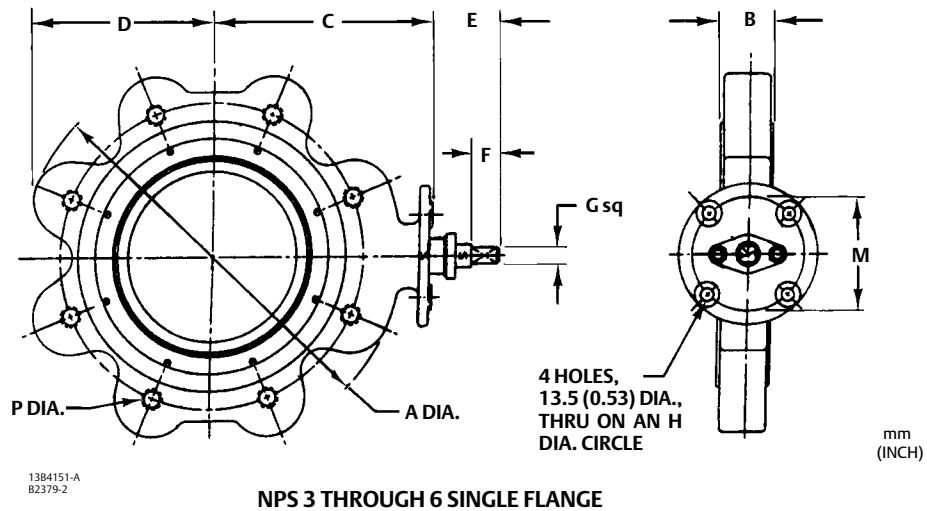
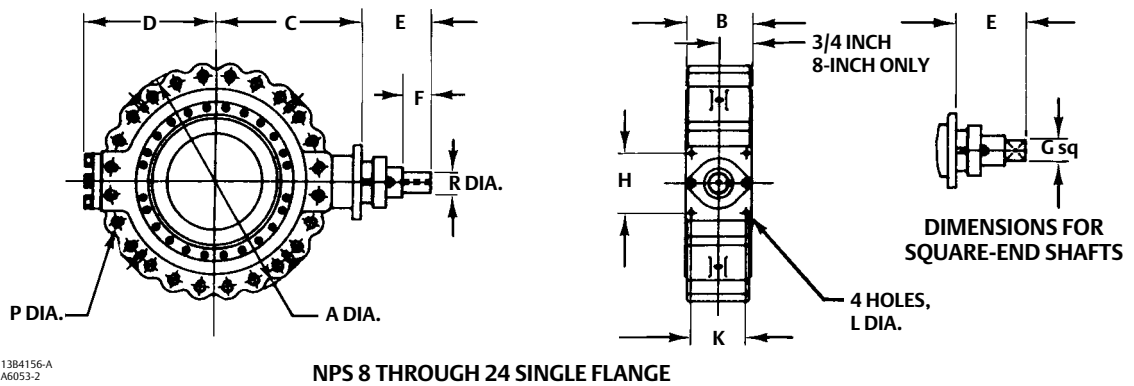

Figure 7. Dimensions Single Flange Style CL600 (also see table 11)



**Table 13. Dimensions and Weights Single Flange Style CL900**

VALVE SIZE, NPS	A	B	C	D	E		F	G Square	H	K	M <sup>(1)</sup>	Rø Keyed	KEY SQ SIZE	APPROX WEIGHT
					Keyed Shaft	Sq Shaft								
<b>mm</b>														<b>kg</b>
6	381	76	233	233	210	90	67	22	235	46	126	25	6	59.0
8	470	109	305	305	210	90	67	35	273	51	164	38	10	120
10	546	146	353	353	210	95	67	35	273	51	182	44	10	210
12	610	229	445	445	295	---	95	---	337	76	165	57	13	450
14	635	216	451	451	295	---	95	---	337	76	208	57	13	444
16	705	241	438	438	314	---	117	---	337	76	217	70	16	513
18	781	273	524	524	314	---	114	---	337	76	<sup>(2)</sup>	70	16	703
20	857	292	695	695	314	---	114	---	305	165	284	70	16	991
24	1041	333	657	657	314	---	117	---	572	203	366	95	22	1628
<b>Inches</b>														<b>lbs</b>
6	15.00	3.00	9.19	9.19	8.25	3.56	2.62	0.87	9.25	1.812	4.98	1.00	1/4	130
8	18.50	4.31	12.00	12.00	8.25	3.75	2.62	1.37	10.75	2.00	6.46	1.50	3/8	264
10	21.50	5.75	13.88	13.88	8.25	3.75	2.62	1.37	10.75	2.00	7.17	1.75	3/8	463
12	24.00	9.00	17.50	17.50	11.62	---	3.75	---	13.25	3.00	6.48	2.25	1/2	993
14	25.00	8.50	17.75	17.75	11.62	---	3.75	---	13.25	3.00	8.17	2.25	1/2	978
16	27.75	9.50	17.25	17.25	12.38	---	4.62	---	13.25	3.00	8.55	2.75	5/8	1132
18	30.76	10.75	20.63	20.63	12.38	---	4.50	---	13.25	3.00	<sup>(2)</sup>	2.75	5/8	1550
20	33.75	11.50	27.38	27.38	12.38	---	4.50	---	12.00	6.50	11.19	2.75	5/8	2185
24	41.00	13.12	25.88	25.88	12.38	---	4.62	---	22.50	8.00	14.40	3.75	7/8	3590

1. M dimension is the disk chordal swing diameter.  
2. Contact your [Emerson Process Management sales office](#).

**Table 14. Dimensions Single Flange Style CL900**

VALVE SIZE, NPS	L	J
	<b>mm</b>	
6	See Thread Info Below	See Thread Info Below
8		
10		
12		
14		
16		
18		
20		
24		
VALVE SIZE, NPS	<b>Inches</b>	
6	5/8-11 4 Holes	1-1/8-8 12 Holes
8	3/4-10 4 Holes	1-3/8-8 12 Holes
10	3/4-10 4 Holes	1-3/8-8 16 Holes
12	7/8-9 4 Holes	1-3/8-8 20 Holes
14	7/8-9 4 Holes	1-1/2-8 20 Holes
16	7/8-9 4 Holes	1-5/8-8 20 Holes
18	1-1/4-7 6 Holes	1-7/8-8 20 Holes
20	1-1/4-7 6 Holes	2-8 20 Holes
24	1-1/4-7 6 Holes	2-1/2-8 20 Holes

**Table 15. Dimensions and Weights Single Flange Style CL1500**

VALVE SIZE, NPS	A	B	C	D	E	F	H	K	M <sup>(1)</sup>	R $\varnothing$ Keyed	KEY SQ SIZE	APPROX WEIGHT
					Keyed Shaft							
<b>mm</b>												
10	584	178	399	399	295	95	337	76	118	57	13	311
12	673	267	445	445	305	105	337	76	(2)	64	16	663
14	754	283	483	483	210	114	337	76	(2)	70	16	810
16	826	321	559	559	314	152	305	152	(2)	70	22	1152
18	914	349	629	629	379	164	508	203	(2)	102	25	1613
20	991	410	682	682	404	171	508	203	(2)	108	25	2250
<b>Inches</b>												
10	23.00	7.00	15.69	15.69	11.62	3.75	13.25	3.00	4.63	2.25	1/2	685
12	26.50	10.50	17.50	17.50	12.00	4.13	13.25	3.00	(2)	2.50	5/8	1462
14	29.69	11.13	19.00	19.00	8.25	4.50	13.25	3.00	(2)	2.75	5/8	1785
16	32.52	12.63	22.00	22.00	12.38	6.00	12.00	6.00	(2)	2.75	7/8	2540
18	36.00	13.75	24.75	24.75	14.94	6.44	20.00	8.00	(2)	4.00	1	3555
20	39.00	16.13	26.84	26.84	15.89	6.75	20.00	8.00	(2)	4.25	1	4960

1. M dimension is the disk chordal swing diameter.  
2. The disk size is less than the face-to-face dimension of this valve. Therefore, the disk chordal swing is not applicable when sizing this valve.

**Table 16. Dimensions Single Flange Style CL1500**

VALVE SIZE, NPS	L	J
	<b>mm</b>	
10	See Thread Info Below	See Thread Info Below
12		
14		
16		
18		
20		
VALVE SIZE, NPS	<b>Inches</b>	
10	7/8-9 4 Holes	1-7/8-8 12 Holes
12	7/8-9 4 Holes	2-8 16 Holes
14	7/8-9 4 Holes	2-1/4-8 16 Holes
16	1-1/4-7 6 Holes	2-1/2-8 16 Holes
18	1-1/4-7 6 Holes	2-3/4-8 16 Holes
20	1-1/4-7 6 Holes	3-8 16 Holes

**Figure 8. Dimensions Single Flange Style CL900 and CL1500 (also see tables 13 and 15)**

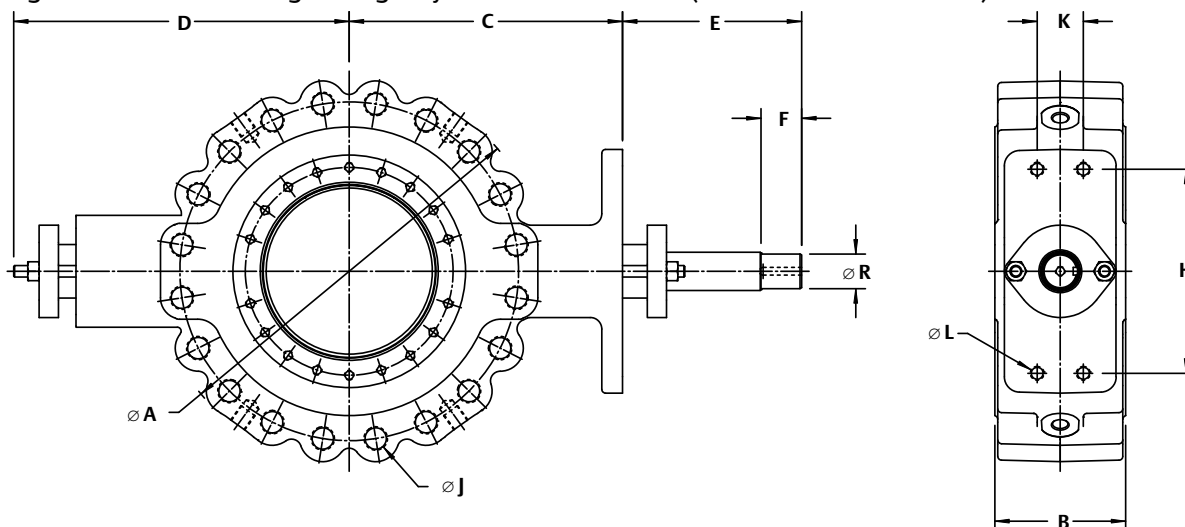

# Pressure Drops

Pressure drop limits of any given valve are based on valve body, and trim material limits. To find the appropriate pressure drop limitation, choose the desired valve size and temperature range. Then search

table 17 for body limitations and tables 18, 19, 20, and 21 for trim limitations. Information on limits for S31254, CW2M, M35-1 and other alloy constructions can be obtained by contacting your [Emerson Process Management sales office](#). The lowest number from the tables is the appropriate limit. The tables for both trim and body limits must be consulted.

**Table 17. Maximum Allowable Shutoff Pressure Drops (Valve Ratings) Based on Carbon Steel and Stainless Steel Valve Types<sup>(1)</sup> (The tables for both trim and body limits must be consulted)**

TEMPERATURE RANGE	PRESSURE RANGE											
	CL150/150		CL150		CL300		CL600		CL900		CL1500	
	WCC	CF8M	WCC	CF8M	WCC	CF8M	WCC	CF8M	WCC	CF8M	WCC	CF8M
°C	Bar											
-254 to -29	---	10.3	---	19.0	---	49.6	---	99.3	---	148.9	---	248.2
-29 to 38	10.3	10.3	20	19.0	51.7	49.6	103.4	99.3	155.1	148.9	258.6	248.2
93	9.3	9.0	17.9	16.2	51.7	42.7	103.4	85.5	155.1	128.2	258.6	213.4
149	8.3	7.9	15.9	14.8	50.3	38.6	100.3	77.2	150.7	115.8	251.0	192.7
204	7.2	7.2	13.8	13.4	48.6	35.5	96.9	70.7	145.5	106.2	242.7	177.2
260	6.2	6.2	11.7	11.7	45.9	33.1	91.7	65.8	137.6	98.9	229.3	164.8
316	5.2	5.2	9.7	9.7	41.7	31.0	83.4	62.1	125.1	93.4	208.6	155.5
343	4.5	4.5	8.6	8.6	40.7	30.3	81.0	61.0	121.7	91.4	202.7	152.4
371	4.1	4.1	7.6	7.6	38.3	30.0	76.5	60.0	114.8	90.0	191.3	149.6
399	3.4	3.4	6.6	6.6	34.8	29.3	70.0	59.0	104.8	88.3	174.8	147.2
427	2.8	2.8	5.5	5.5	28.3	29.0	56.9	58.3	85.2	87.2	141.7	145.5
454	---	2.4	---	4.5	---	29.0	---	57.6	---	86.5	---	144.1
482	---	1.7	---	3.4	---	28.6	---	57.2	---	85.8	---	143.1
510	---	1.4	---	2.4	---	26.5	---	53.4	---	80.0	---	133.1
538	---	0.7	---	1.4	---	25.2	---	50.0	---	75.2	---	125.5
°F	Psi											
-450 to -20	---	150	---	275	---	720	---	1440	---	2160	---	3600
-20 to 100	150	150	290	275	750	720	1500	1440	2250	2160	3750	3600
200	135	130	260	235	750	620	1500	1240	2250	1860	3750	3095
300	120	115	230	215	730	560	1455	1120	2185	1680	3640	2795
400	105	105	200	195	705	515	1405	1025	2110	1540	3520	2570
500	90	90	170	170	665	480	1330	955	1995	1435	3325	2390
600	75	75	140	140	605	450	1210	900	1815	1355	3025	2255
650	65	65	125	125	590	440	1175	885	1765	1325	2940	2210
700	60	60	110	110	555	435	1110	870	1665	1305	2775	2170
750	50	50	95	95	505	425	1015	855	1520	1280	2535	2135
800	40	40	80	80	410	420	825	845	1235	1265	2055	2110
850	---	35	---	65	---	420	---	835	---	1255	---	2090
900	---	25	---	50	---	415	---	830	---	1245	---	2075
950	---	20	---	35	---	385	---	775	---	1160	---	1930
1000	---	10	---	20	---	365	---	725	---	1090	---	1820

1. For pressure/temperature rating of other materials, contact your [Emerson Process Management sales office](#).



**Table 18. Maximum Allowable Shutoff Pressure Drops<sup>(1)</sup>**

TRIM NUMBER	TEMPERATURE RANGE	PRESSURE RANGE											
		CL150/150				CL150				CL300			
		Valve Body Size, NPS				Valve Body Size, NPS				Valve Body Size, NPS			
		30	36	42	48	30	36	42	48	30	36	42	48
°C	Bar												
550	-46 to 38	10.34	10.34	10.34	10.34	32.06	27.85	18.55	12.34	38.47	51.02	46.06	51.02
	38 to 149	10.34	10.34	10.34	10.34	27.58	27.58	18.55	12.34	27.58	27.58	27.58	27.58
	149 to 232	3.447	3.447	3.447	3.447	3.447	3.447	3.447	3.447	3.447	3.447	3.447	3.447
552	-46 to 38	10.34	10.34	10.34	10.34	29.72	23.72	16.27	11.17	32.82	45.44	41.23	61.64
	38 to 149	10.34	10.34	10.34	10.34	25.72	23.72	16.27	11.17	32.82	45.44	41.23	61.64
	149 to 232	10.34	10.34	10.34	10.34	24.2	23.72	16.27	11.17	32.82	45.44	41.23	61.09
554	-46 to 38	10.34	8.136	10.34	4.964	21.24	16	9.584	5.792	26.48	35.78	31.37	48.06
	38 to 149	10.34	8.136	10.34	4.964	17.93	16	9.584	5.792	26.48	35.78	31.37	39.64
	149 to 232	10.34	8.136	10.34	4.964	16.75	16	9.584	5.792	20.68	20.68	20.68	20.68
555, 556	-46 to 38	10.34	10.34	10.34	7.722	22.75	16.62	11.45	7.653	22.75	32.47	29.51	44.33
	38 to 149	10.34	10.34	10.34	7.722	19.65	16.62	11.45	7.653	22.75	32.47	29.51	44.33
	149 to 232	10.34	10.34	10.34	7.722	18.48	16.62	11.45	7.653	22.75	32.47	29.51	44.33
556	232 to 316	10.34	10.34	10.34	7.722	17.65	16.96	11.45	7.653	22.75	32.47	29.51	44.33
556	316 to 427	10.34	10.34	10.34	7.446	16.89	16.62	11.17	7.446	22.75	32.47	29.51	44.33
564H, 566H	343 to 427	10.34	10.34	10.34	7.722	16.89	16.96	11.45	7.653	22.75	32.54	29.51	44.33
564H <sup>(2)</sup> , 566H	427 to 538	10.34	10.34	10.34	7.722	24.55	16.96	11.45	7.653	22.75	32.54	29.51	44.33
567C	-196 to -46	10.34	10.34	10.34	10.34	26.34	28.89	20.82	14.34	41.78	55.23	46.61	56.95
	-46 to 149	10.34	10.34	10.34	10.34	17.24	22.89	16.89	14.34	41.78	43.99	36.89	45.23
TRIM NUMBER	°F	Psi											
550	-50 to 100	150	150	150	150	465	404	269	179	558	740	668	740
	100 to 300	150	150	150	150	400	400	269	179	400	400	400	400
	300 to 450	50	50	50	50	50	50	50	50	50	50	50	50
552	-50 to 100	150	150	150	150	431	344	236	162	476	659	598	894
	100 to 300	150	150	150	150	373	344	236	162	476	659	598	894
	300 to 450	150	150	150	150	351	344	236	162	476	659	598	886
554	-50 to 100	150	118	150	72	308	232	139	84	384	519	455	697
	100 to 300	150	118	150	72	260	232	139	84	384	519	455	575
	300 to 450	150	118	150	72	243	232	139	84	300	300	300	300
555, 556	-50 to 100	150	150	150	112	330	241	166	111	330	471	428	643
	100 to 300	150	150	150	112	285	241	166	111	330	471	428	643
	300 to 450	150	150	150	112	268	241	166	111	330	471	428	643
	450 to 600	150	150	150	112	256	246	166	111	330	471	428	643
556	600 to 800	150	150	150	108	245	241	162	108	330	471	428	643
564H, 566H	650 to 800	150	150	150	112	245	246	166	111	330	472	428	643
564H <sup>(2)</sup> , 566H	800 to 1000	150	150	150	112	356	246	166	111	330	472	428	643
567C	-320 to -50	150	150	150	150	382	419	302	208	606	801	676	826
	-50 to 300	150	150	150	150	250	332	245	208	606	638	535	656

1. Consult your [Emerson Process Management sales office](#) if higher pressure drops are required.  
2. Trim 564H with optional N07718 shaft for temperatures up to 482°C. (1000°F).

Table 19. Maximum Allowable Shutoff Pressure Drops, CL600<sup>(1)</sup>

TRIM NUMBER	TEMP RANGE	NPS 3	NPS 4	NPS 6	NPS 8	NPS 10	NPS 12	NPS 14	NPS 16	NPS 18	NPS 20	NPS 24	
	°C												
		Bar											
500	-46 to 38	98.9	103.1	103.4	103.4	99.1	103.4	103.4	103.4	103.4	103.4	103.4	60.9
	38 to 93	75.8	75.8	75.8	75.8	75.8	75.8	75.8	75.8	75.8	75.8	75.8	60.9
	93 to 121	41.4	41.4	41.4	41.4	41.4	41.4	41.4	41.4	41.4	41.4	41.4	41.4
	121 to 149	6.9	6.9	6.9	6.9	6.9	6.9	6.9	6.9	6.9	6.9	6.9	6.9
502	-46 to 38	95.0	100.4	103.4	103.4	98.0	92.2	103.4	103.4	103.4	94.8	55.2	
	38 to 232	82.3	87.6	82.1	95.1	86.9	74.1	103.4	103.4	103.4	94.8	55.2	
504	-46 to 38	93.1	100.1	103.4	103.4	98.1	87.1	103.4	103.4	103.4	84.7	46.2	
	38 to 93	79.5	94.3	96.5	96.5	93.0	79.2	96.5	96.5	96.5	84.7	46.2	
	93 to 121	62.1	62.1	62.1	62.1	62.1	62.1	62.1	62.1	62.1	62.1	46.2	
	121 to 149	20.7	20.7	20.7	20.7	20.7	20.7	20.7	20.7	20.7	20.7	20.7	
506	-46 to 38	91.8	98.4	75.4	103.4	95.6	65.7	103.4	103.4	93.3	67.2	38.1	
	38 to 343	62.1	78.9	51.4	76.5	82.2	48.4	101.8	83.2	93.3	67.2	38.1	
	343 to 427	58.7	75.1	48.8	73.3	80.5	46.5	98.5	80.5	93.3	67.2	38.1	
514H, 516H	343 to 427	58.7	75.1	48.8	73.3	80.5	46.5	98.5	80.5	93.3	67.2	38.1	
514H <sup>(2)</sup> , 516H	427 to 538	97.8	103.4	83.6	103.4	101.2	71.7	103.4	103.4	93.4	67.2	38.1	
517C	-196 to 163	Consult your <a href="#">Emerson Process Management sales office</a> .											
517C <sup>(3)</sup>	-196 to -129	88.4	92.3	100.2	98.7	89.9	103.4	103.4	103.4	103.4	103.4	78.3	
	-129 to -46	79.6	83.2	90.3	89.1	81.6	94.8	102.3	103.4	103.4	103.4	78.3	
	-46 to 38	67.6	70.7	76.7	76.3	70.3	77.6	88.6	93.1	94.5	103.4	78.3	
	38 to 149	61.2	64.1	69.5	69.4	64.3	66.7	81.2	85.1	86.3	96.5	78.3	
TRIM NUMBER	°F	Psi											
500	-50 to 100	1435	1495	1500	1500	1437	1500	1500	1500	1500	1500	1500	883
	100 to 200	1100	1100	1100	1100	1100	1100	1100	1100	1100	1100	1100	883
	200 to 250	600	600	600	600	600	600	600	600	600	600	600	600
	250 to 300	100	100	100	100	100	100	100	100	100	100	100	100
502	-50 to 100	1378	1456	1500	1500	1422	1337	1500	1500	1500	1375	800	
	100 to 450	1194	1270	1191	1380	1260	1075	1500	1500	1500	1375	800	
504	-50 to 100	1350	1453	1500	1500	1422	1264	1500	1500	1500	1229	670	
	100 to 200	1153	1368	1400	1400	1349	1148	1400	1400	1400	1229	670	
	200 to 250	900	900	900	900	900	900	900	900	900	900	670	
	250 to 300	300	300	300	300	300	300	300	300	300	300	300	
506	-50 to 100	1331	1427	1093	1500	1401	953	1500	1500	1353	974	553	
	100 to 650	900	1144	746	1110	1192	702	1477	1206	1353	974	553	
	650 to 800	852	1089	708	1064	1167	675	1429	1168	1353	974	553	
514H, 516H	650 to 800	852	1089	708	1064	1167	675	1429	1168	1353	974	553	
514H <sup>(2)</sup> , 516H	800 to 1000	1418	1500	1213	1500	1468	1040	1500	1500	1354	974	553	
517C	-320 to 325	Consult your <a href="#">Emerson Process Management sales office</a> .											
517C <sup>(3)</sup>	-320 to -200	1282	1339	1454	1431	1304	1500	1500	1500	1500	1500	1135	
	-200 to -50	1155	1206	1309	1293	1184	1375	1484	1500	1500	1500	1135	
	-50 to 100	980	1025	1113	1106	1020	1126	1285	1350	1371	1500	1135	
	100 to 300	887	929	1008	1006	933	967	1178	1234	1251	1400	1135	

1. Consult your Emerson Process Management sales office if higher pressure drops are required.  
 2. Trim 514H with optional N07718 shaft for temperatures up to 482°C (1000°F).  
 3. Trim 517C with optional CTFE cryogenic seal without backup ring.

Table 20. Maximum Allowable Shutoff Pressure Drops, CL900<sup>(1,2)</sup>

TRIM NUMBER	TEMP RANGE	NPS 6	NPS 8	NPS 10	NPS 12	NPS 14	NPS 16	NPS 18	NPS 20	NPS 24
	°C									
500	-46 to 38	103.4	103.4	103.4	103.4	103.4	103.4	103.4	103.4	103.4
	38 to 93	75.8	75.8	75.8	75.8	75.8	75.8	75.8	75.8	75.8
	93 to 121	41.4	41.4	41.4	41.4	41.4	41.4	41.4	41.4	41.4
	121 to 149	6.9	6.9	6.9	6.9	6.9	6.9	6.9	6.9	6.9
502	-46 to 38	100.0	155.1	110.7	155.1	146.6	154.2	151.9	120.0	128.7
	38 to 149	84.6	146.2	110.7	150.7	146.5	139.3	139.1	120.0	128.6
	149 to 232	78.8	140.4	110.7	141.7	141.7	131.5	134.1	120.0	128.7
504	-46 to 38	103.4	103.4	103.4	103.4	103.4	103.4	103.4	91.0	92.8
	38 to 93	96.5	96.5	96.5	96.5	96.5	96.5	96.5	91.0	92.8
	93 to 121	62.1	62.1	62.1	62.1	62.1	62.1	62.1	62.1	62.1
	121 to 149	20.7	20.7	20.7	20.7	20.7	20.7	20.7	20.7	20.7
506	-46 to 38	81.1	122.2	78.5	131.3	104.1	119.8	118.7	82.5	89.9
	38 to 149	67.6	122.2	78.5	131.3	104.1	103.4	118.7	82.5	89.9
	149 to 232	62.6	122.2	78.5	131.3	104.1	97.4	118.7	82.5	89.9
	232 to 343	58.1	121.3	78.5	121.3	104.1	91.8	118.7	82.5	89.9
	343 to 427	55.5	105.1	78.5	105.1	104.1	88.7	105.1	82.5	89.9
514H, 516H	343 to 427	55.5	105.1	78.5	105.1	104.1	88.7	105.1	82.5	89.9
514H <sup>(3)</sup> , 516H	427 to 538	70.4	62.5	58.7	88.0	48.9	39.1	37.2	52.8	43.0
TRIM NUMBER	°F	Psi								
500	-50 to 100	1500	1500	1500	1500	1500	1500	1500	1500	1500
	100 to 200	1100	1100	1100	1100	1100	1100	1100	1100	1100
	200 to 250	600	600	600	600	600	600	600	600	600
	250 to 300	100	100	100	100	100	100	100	100	100
502	-50 to 100	1451	2250	1606	2250	2126	2237	2203	1741	1866
	100 to 300	1227	2120	1606	2185	2125	2020	2017	1741	1865
	300 to 450	1143	2036	1606	2055	2055	1907	1945	1741	1866
504	-50 to 100	1500	1500	1500	1500	1500	1500	1500	1320	1346
	100 to 200	1400	1400	1400	1400	1400	1400	1400	1320	1346
	200 to 250	900	900	900	900	900	900	900	900	900
	250 to 300	300	300	300	300	300	300	300	300	300
506	-50 to 100	1176	1773	1138	1905	1510	1737	1721	1197	1304
	100 to 300	980	1773	1138	1905	1510	1500	1721	1197	1304
	300 to 450	908	1773	1138	1905	1510	1412	1721	1197	1304
	450 to 650	842	1760	1138	1760	1510	1332	1721	1197	1304
	650 to 800	805	1525	1138	1525	1510	1286	1525	1197	1304
514H, 516H	650 to 800	805	1525	1138	1525	1510	1286	1525	1197	1304
514H <sup>(3)</sup> , 516H	800 to 1000	1021	907	851	1276	709	567	539	766	624

1. Consult your [Emerson Process Management sales office](#) if higher pressure drops are required.  
2. Consult [Bulletin 59.3:042 Packing Selection Guidelines for Rotary Valves, D102093X012](#) for packing selection guidelines regarding pressure/temperature limits.  
3. Trim 514H with optional N07718 shaft.

Table 21. Maximum Allowable Shutoff Pressure Drops, CL1500<sup>(1, 2)</sup>

TRIM NUMBER	TEMP RANGE	NPS 10	NPS 12	NPS 14	NPS 16	NPS 18	NPS 20
	°C	Bar					
500	-46 to 38	103.4	103.4	103.4	103.4	103.4	103.4
	38 to 93	75.8	75.8	75.8	75.8	75.8	75.8
	93 to 121	41.4	41.4	41.4	41.4	41.4	41.4
	121 to 149	6.9	6.9	6.9	6.9	6.9	6.9
502	-46 to 38	179.0	248.1	169.4	201.5	249.7	243.0
	38 to 149	155.0	226.5	169.5	201.5	228.1	222.1
	149 to 232	146.1	218.2	169.5	201.5	219.7	214.0
504	-46 to 38	103.4	103.4	103.4	103.4	103.4	103.4
	38 to 93	96.5	96.5	96.5	96.5	96.5	96.5
	93 to 121	62.1	62.1	62.1	62.1	62.1	62.1
	121 to 149	20.7	20.7	20.7	20.7	20.7	20.7
506	-46 to 38	133.5	186.2	116.5	139.5	235.4	174.7
	38 to 149	114.2	186.2	116.5	139.5	224.8	174.7
	149 to 232	107.1	186.2	116.5	139.5	216.3	174.7
	232 to 343	100.6	186.2	116.5	139.5	202.2	174.7
	343 to 427	96.9	175.1	116.5	139.5	175.1	174.7
514H, 516H	343 to 427	96.9	175.1	116.5	139.5	175.1	174.8
514H <sup>(3)</sup> , 516H	427 to 538	78.2	70.4	86.0	78.2	66.5	74.3
TRIM NUMBER	°F	Psi					
500	-50 to 100	1500	1500	1500	1500	1500	1500
	100 to 200	1100	1100	1100	1100	1100	1100
	200 to 250	600	600	600	600	600	600
	250 to 300	100	100	100	100	100	100
502	-50 to 100	2596	3599	2457	2922	3622	3525
	100 to 300	2248	3285	2458	2922	3309	3221
	300 to 450	2119	3164	2458	2922	3187	3104
504	-50 to 100	1500	1500	1500	1500	1500	1500
	100 to 200	1400	1400	1400	1400	1400	1400
	200 to 250	900	900	900	900	900	900
	250 to 300	300	300	300	300	300	300
506	-50 to 100	1936	2700	1689	2024	3414	2534
	100 to 300	1657	2700	1689	2024	3260	2534
	300 to 450	1553	2700	1689	2024	3137	2534
	450 to 650	1459	2700	1689	2024	2933	2534
	650 to 800	1405	2540	1689	2024	2540	2534
514H, 516H	650 to 800	1406	2540	1689	2024	2540	2535
514H <sup>(3)</sup> , 516H	800 to 1000	1134	1021	1248	1134	964	1077

1. Consult your Emerson Process Management sales office if higher pressure drops are required.  
 2. Consult Bulletin 59.3:042 Packing Selection Guidelines for Rotary Valves, D102093X012 for packing selection guidelines regarding pressure/temperature limits.  
 3. Trim 514H with optional N07718 shaft.

Neither Emerson, Emerson Process Management, nor any of their affiliated entities assumes responsibility for the selection, use or maintenance of any product. Responsibility for proper selection, use, and maintenance of any product remains solely with the purchaser and end user.

Fisher, ENVIRO-SEAL, Bettis, FieldQ and Hytork are marks owned by one of the companies in the Emerson Process Management business unit of Emerson Electric Co. Emerson Process Management, Emerson, and the Emerson logo are trademarks and service marks of Emerson Electric Co. All other marks are the property of their respective owners.

The contents of this publication are presented for informational purposes only, and while every effort has been made to ensure their accuracy, they are not to be construed as warranties or guarantees, express or implied, regarding the products or services described herein or their use or applicability. All sales are governed by our terms and conditions, which are available upon request. We reserve the right to modify or improve the designs or specifications of such products at any time without notice.

Emerson Process Management  
 Marshalltown, Iowa 50158 USA  
 Sorocaba, 18087 Brazil  
 Cernay, France 68700  
 Dubai, United Arab Emirates  
 Singapore 128461 Singapore

www.Fisher.com

