



IWAKI
Self-priming
Magnetic Drive Pumps

SMX

Main material
GFRPP



Patent

JAPAN / U.S.A. / EU / CHINA / TAIWAN

Solutions for chemical handling applications

Versatile self-priming magnetic drive pump with enhanced durability under abnormal operation



The SMX is a horizontal self-priming magnetic drive pump made from reinforced plastic. Our original self-radiation structure (Patented) enhances resistance to dry running, cavitation, and closed-discharge operation. In addition, the use of standard motors extends the range of application.



SMX-543

SMX-441

SMX-220

Expanded versatility

The SMX has a modular structure to handle liquids with high specific gravities. Use of standard motors extends the range of liquid application.

Easy maintenance

The pump wet end can be removed from the motor as a complete assembly without dismantling, thanks to an additional rear casing support. The pump wet end comprises the minimum number of parts for easy maintenance.

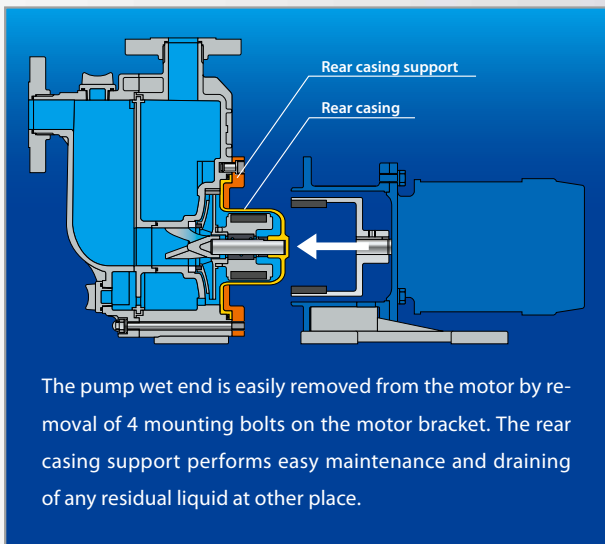

Enhanced durability under abnormal operation

Our original self-radiation structure (Patented) efficiently disperses bearing friction heat to protect the pump under abnormal operating conditions. In addition, our non-contact structure prevents contact between rear thrust face and bearing, to eliminate heat buildup during dry running.

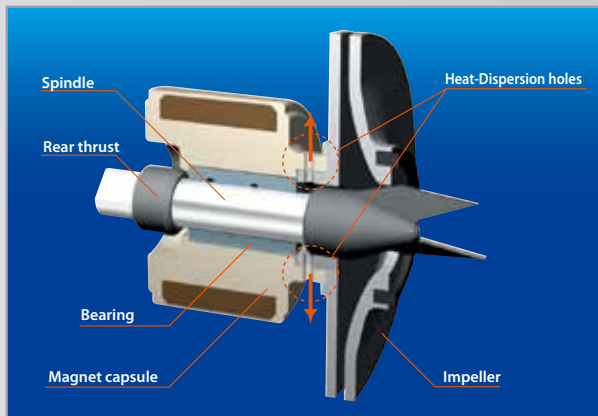

Fast self-priming

The SMX requires no external self-priming chambers or valves. The gas-liquid separation design ensures fast self-priming. An exceptional self-priming duration of up to 4m in only 90 seconds is now possible.

Examples of application

Pumping up from underground tank

- Underground tank at chemical plant.
- Underground tank or pit of waste plant.

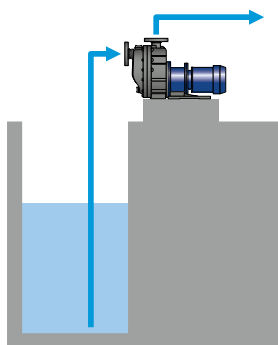

Pumping up and out from top of tank and tanker truck

- Transferring etching and plating chemical from chemical bath.
- Sucking up chemical from truck.
- Pumping up from top of tank.

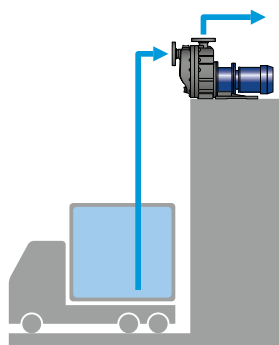

Transferring chemical from tank to tank

- Transferring from main tank to daily tank.
- Refilling chemical from drum to tank.

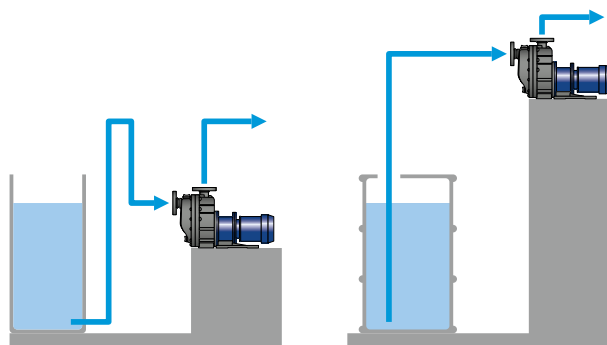

Reliability and performance are enhanced by our unique design

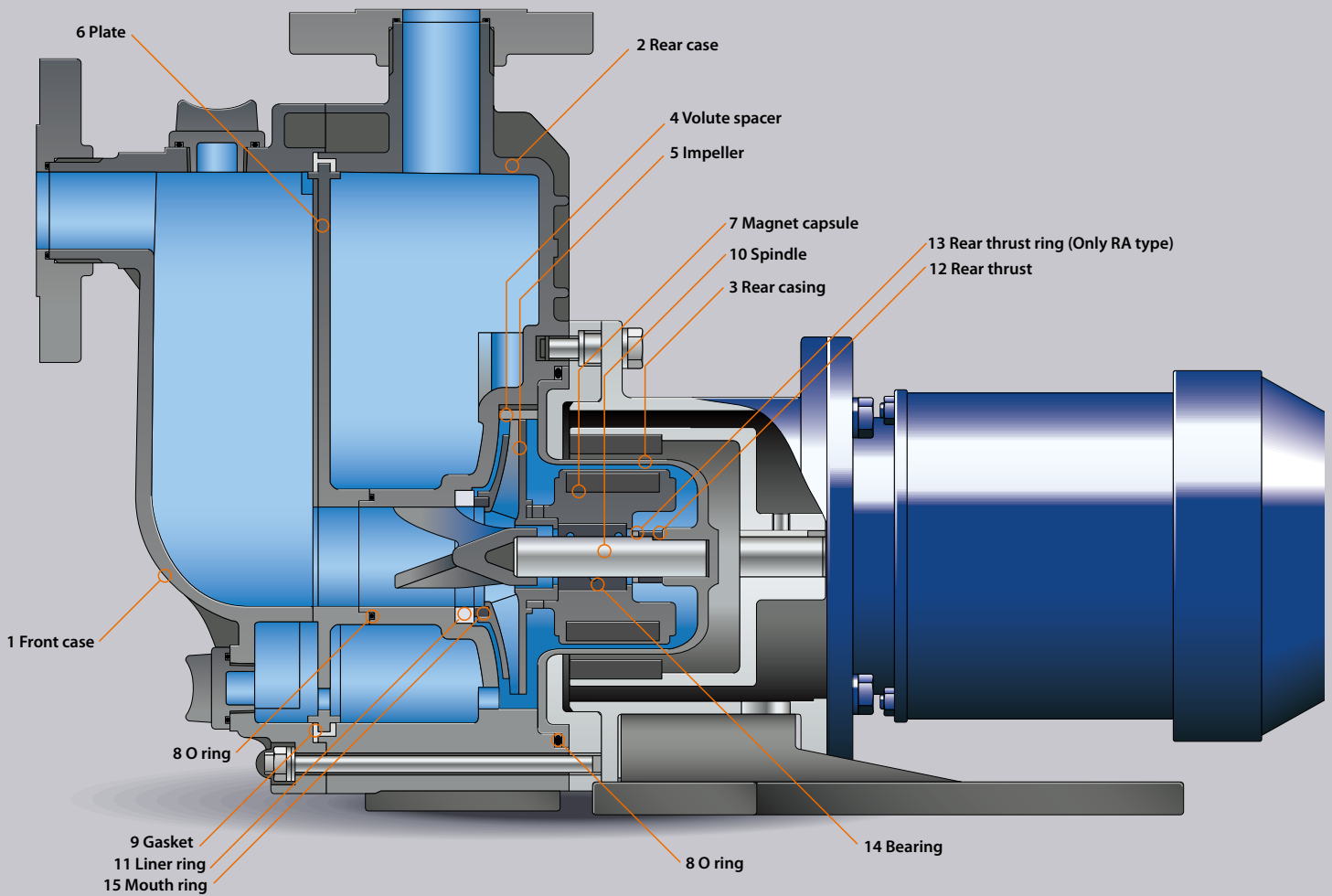

Wet-end materials

Name of part	Model		
	CA	RA	KA
1 Front case			
2 Rear case			
3 Rear casing		GFRPP	
4 Volute spacer <small>Note1</small>			
5 Impeller			
6 Plate			
7 Magnet capsule		PP	
8 O ring		FKM/EPDM	
9 Gasket			
10 Spindle	High purity alumina ceramic		SiC
11 Liner ring		Alumina ceramic	
12 Rear thrust <small>SMX-22, 44</small>		CFRPPS	
<small>SMX-54</small>	High purity alumina ceramic		SiC
13 Rear thrust ring <small>Note2</small>	-	Alumina ceramic	-
14 Bearing	Carbon	PTFE (With filler)	SiC
15 Mouth ring		PTFE (With filler)	

Note1 : SMX-22□T, 54□T, 54□X do not have a Volute spacer
 Note2 : Exclusive for SMX-22RA, 44RA



Principles of Self-Priming

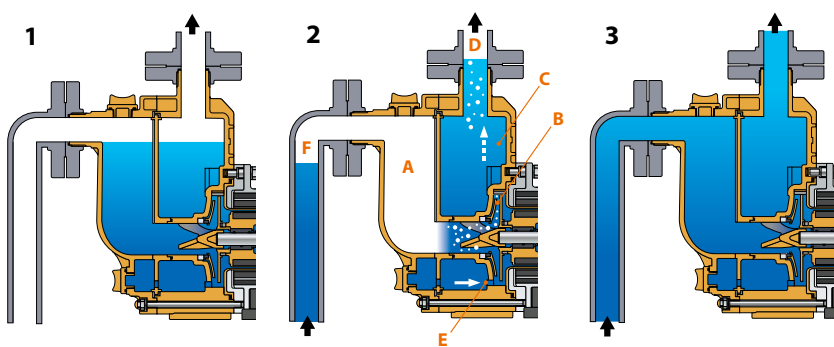

1 Prime the pump with liquid.

2 On starting, the pump will suck both gas and liquid into its inlet. This mixture moves through front case **A** to the front casing, where it is agitated by the impeller. The mixture is discharged through pump chamber **B** to rear case **C**, where gas and liquid separation then occurs. Gas is bled from the discharge port **D** while some liquid is retained. Liquid in the rear case **C** is fed back through circulation hole **E** to the front casing, where it is again mixed with entrained gas by the impeller. This recirculation & bleeding process continues until gas from the suction side **F** is completely expelled.

3 Once all gas is expelled, normal centrifugal pump operation is resumed. Sufficient liquid remains in the casing for subsequent self-priming once the pump is stopped.

Specifications

50Hz

Model	Connection Suction X Discharge (mm)	Impeller	Min. capacity (L/min)	Standard specification (L/min-m)	Max. capacity (L/min)	Motor (kW 2p)	Resisting pressure limit (MPa)	Mass (Less motor) (kg)
SMX-220	25 X 25	V	10	80 - 8.5	90	0.37	0.28	13
SMX-221		T		100 - 13.0	160	0.75		15.5
SMX-222		V		80 - 8.5	140	1.5		16
SMX-441	40 X 40	T	10	150 - 12.4	190	0.75	0.33	16
SMX-442		T		150 - 12.4	280	1.5		16.5
SMX-542	50 X 40	V	20	200 - 17.0	230	1.5	0.43	24
SMX-543		T		250 - 18.0	440	2.2		
		V		200 - 17.0	410			
		T		250 - 18.0	440			
SMX-545		V		200 - 17.0	410	4.0		32

• The self-priming height limit noted above refers to a liquid equivalent to fresh water at 20°C. The self-priming height limit varies with the liquid temperature and the type of liquid.
 • Temperature range of handled liquid: 0 to 80°C (The self-priming height limit decreases at high temperatures.)

Pump identification

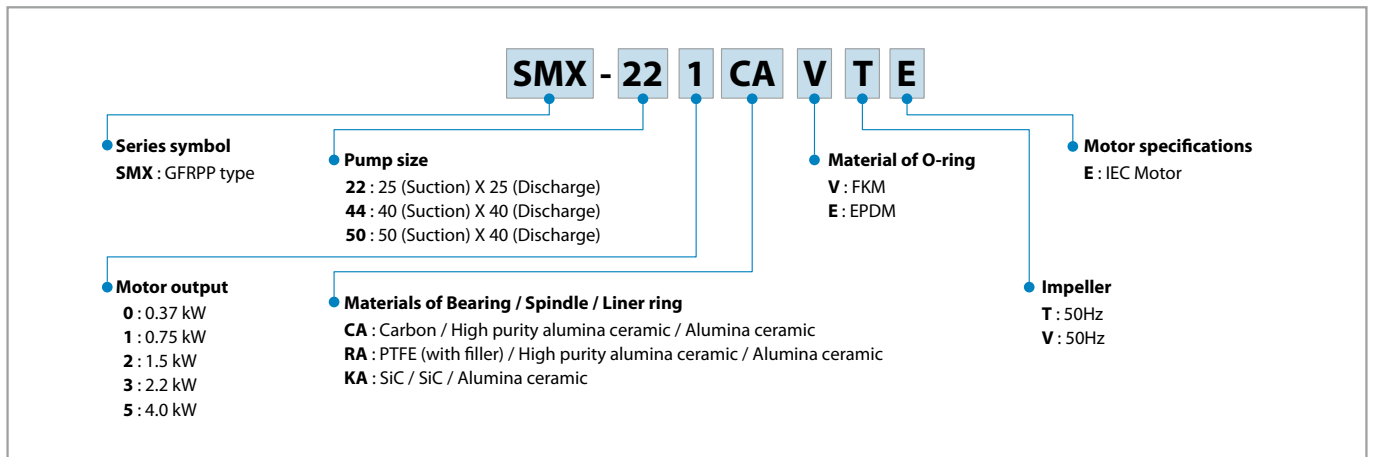

Precautions on the selection of pumps

- The performance curves on this catalogue are based on the operation with 20°C clean water in flooded suction. Keep a margin (3% of the curves) when selecting the pump.
- The magnetic pump cannot run continuously with a closed-discharge. Be sure to observe the minimum flow rate.
 The minimum flow rate SMX-22□: 10L/min
 SMX-44□: 10L/min
 SMX-54□: 20L/min
- Select a pump model according to liquid specific gravity. Keep a margin (5% or more) for motor output.
 Pump shaft power $Sp \times \text{Specific gravity} \times 1.05$ or more (margin) \leq Motor output
- The self-priming performance (4m in 90 seconds) is based on the operation with 20°C clean water on the right piping condition. Self-priming performance varies with liquid temperature, characteristics and piping conditions. Obtain a rough guide of the highest possible self-priming height at each liquid specific gravity by the following formula.
 The highest possible self-priming height[m] = Self-priming height with clean water[m] / Liquid specific gravity

Self-priming considerations

- The diameter of the piping on the suction side should be the same as that of the pumps inlet port,
 SMX-22□: 25mm
 SMX-44□: 40mm
 SMX-54□: 50mm
 and the length of the piping should be limited to less than 4.7m. A larger pipe diameter or longer piping could adversely affect the self-priming performance, or could even hinder the self-priming process itself.
- In cases where the liquid level fluctuates, take the height from the lowest liquid level as the maximum self-priming height.
- Always perform priming before first operation, and start the pump only after the pump chamber has been filled with the handled liquid.
- To prevent early deterioration, avoid frequent start/stop of the pump.
- If a foot valve is installed on the suction pipe, pipe resistance may increase so that the pump cannot suck liquid enough.

Performance curves

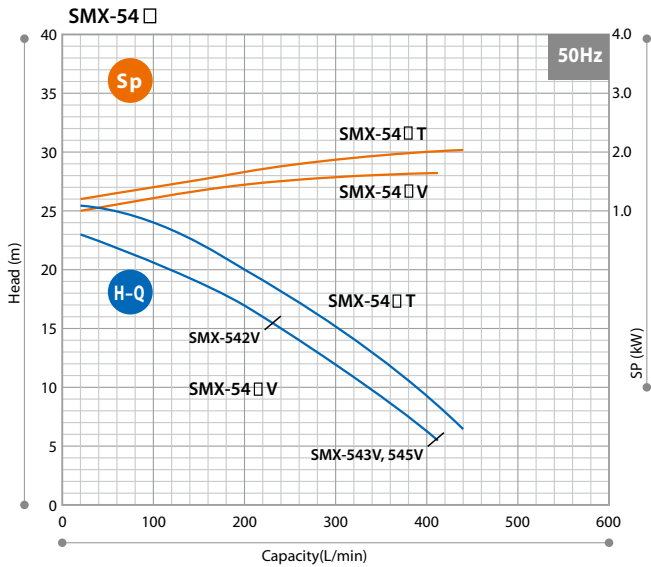
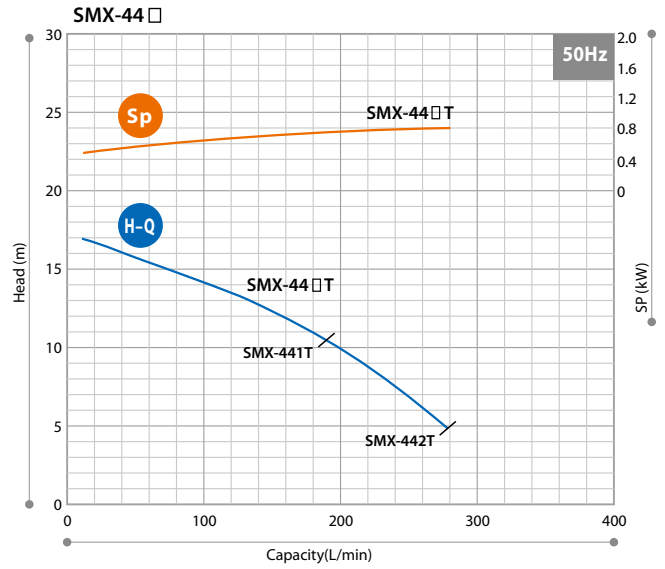
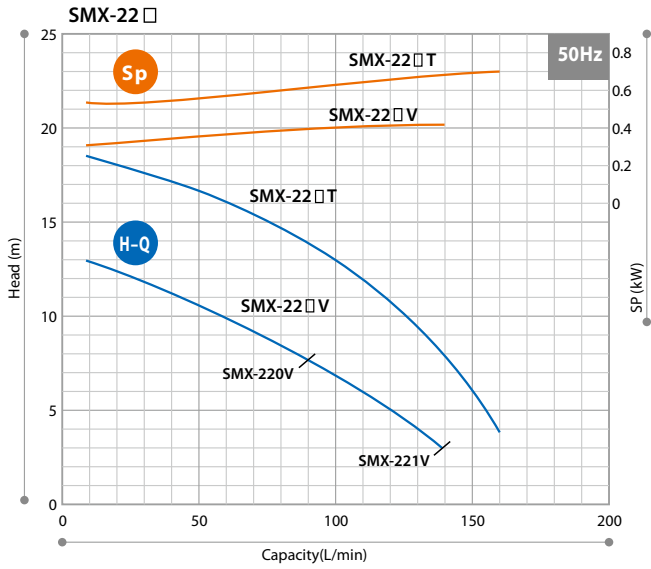

Dimensions in mm

**SMX -220, 221, 222
-441, 442
-542, 543**

SMX -545

model	H	L	a	b	c	d	e	f	g	h	i
SMX-220	(329)	(539)	ø125	ø25	ø125	ø25	(162)	(74)	255	(240)	(308)
SMX-221	(329)	(553)	ø125	ø25	ø125	ø25	(162)	(74)	255	(240)	(320)
SMX-222	(329)	(607)	ø125	ø25	ø125	ø25	(162)	(74)	255	(240)	(332)
SMX-441	(364)	(599)	ø140	ø40	ø140	ø40	(188)	(93)	271	(285)	(366)
SMX-442	(364)	(652)	ø140	ø40	ø140	ø40	(188)	(93)	271	(285)	(378)
SMX-542	(390)	(668)	ø140	ø40	ø155	ø50	(205)	(100)	290	(315)	(393)
SMX-543	(390)	(668)	ø140	ø40	ø155	ø50	(205)	(100)	290	(315)	(393)
SMX-545	(390)	(736)	ø140	ø40	ø155	ø50	(205)	(100)	290	(315)	(413)

The dimensions L may differ with the type of motor installed.

Optional accessories

Iwaki dry running protector DR series

Model DR is electric current sensing type dry running protector. It detects the decreased load current (lower limit) to stop the pump when it runs dry or runs with air sucking in. It can detect over-load, too.

- Current figure to be set is indicated on LCD.
- Both top/bottom figures can be set.
Top:Over-load
Bottom:Dry running, air sucking-in operation, operation with suction side closed
- Built-in current transformer
- DIN rail mounting
- It is unable to use DR when inverter is employed in the system.



Specification

50Hz

Model	DR-20	
Motor power	200 to 240V three phase	380 to 440V three phase
Applied motor	0.37kW to 0.75kW	0.75kW to 15kW
Power control	100V to 240V single phase	
Power	V	200V to 240V ±10%single phase
	Input	3.5W
Detective current	0.5A to 32.0A	
Current transformer (CT)	Built-in	
Outer dimension	D80 X W153 X H122	

Iwaki process magnetic drive pump series

MX/MX-F SERIES

Withstands difficult operating conditions and offers high efficiency



MX-401

MX-250

Specifications

- Max.discharge capacity: 500 L/min
- Max.head: 35 m
- Main materials: GFRPP (MX-F: CFRETFE)
- Liquid temp. range: 0 to 80 °C

MXM SERIES

Magnetic drive pumps with an excellent balance of features and performance



MXM542

Specifications

- Max.discharge capacity: 600 L/min
- Max.head: 29 m
- Main materials: CFRETFE
- Liquid temp. range: -10 to 105 °C

IWAKI CO., LTD. 6-6 Kanda-Sudacho 2-chome Chiyoda-ku Tokyo 101-8558 Japan
TEL : (81)3 3254 2935 FAX : 3 3252 8892

()Country codes

IWAKI has global net work. Please find your distributor location at

www.iwaki pumps.jp

European office : IWAKI Europe GmbH
Germany : IWAKI Europe GmbH
Holland : IWAKI Europe GmbH (Netherlands Branch)
Italy : IWAKI Europe GmbH (Italy Branch)
Spain : IWAKI Europe GmbH (Spain Branch)
Belgium : IWAKI Belgium N.V.
Denmark : IWAKI Nordic A/S
Finland : IWAKI Suomi Oy
France : IWAKI France S.A.
Norway : IWAKI Norge AS
Sweden : IWAKI Sverige AB
U.K. : IWAKI Pumps (UK) Ltd.

TEL: (49)2154 9254 0 FAX: 2154 9254 48
TEL: (49)2154 9254 50 FAX: 2154 9254 55
TEL: (31)74 2420011 FAX: (49)2154 925448
TEL: (39)0444 371115 FAX: 0444 335350
TEL: (34)93 37 70 198 FAX: 93 47 40 991
TEL: (32)13 67 02 00 FAX: 13 67 20 30
TEL: (45)48 24 2345 FAX: 48 24 2346
TEL: (358)9 2745810 FAX: 9 2742715
TEL: (33)1 69 63 33 70 FAX: 1 64 49 92 73
TEL: (47)23 38 49 00 FAX: 23 38 49 01
TEL: (46)8 511 72900 FAX: 8 511 72922
TEL: (44)1743 231363 FAX: 1743 366507

U.S.A. : IWAKI America Inc. TEL: (1)508 429 1440 FAX: 508 429 1386
Argentina : IWAKI America Inc. (Argentina Branch) TEL: (54)11 4745 4116
Singapore : IWAKI Singapore Pte Ltd. TEL: (65)6316 2028 FAX: 6316 3221
Indonesia : IWAKI Singapore (Indonesia Branch) TEL: (62)21 6906606 FAX: 21 6906612
Malaysia : IWAKI Sdn. Bhd. TEL: (60)3 7803 8807 FAX: 3 7803 4800
Australia : IWAKI Pumps Australia Pty Ltd. TEL: (61)2 9899 2411 FAX: 2 9899 2421
Hong Kong : IWAKI Pumps Co., Ltd. TEL: (852)2607 1168 FAX: 2607 1000
China : GFTZ IWAKI Engineering & Trading Co., Ltd. TEL: (86)20 84350603 FAX: 20 84359181
 : IWAKI Pumps (Shanghai) Co., Ltd. TEL: (86)21 6272 7502 FAX: 21 6272 6929
Korea : IWAKI Korea Co.,Ltd. TEL: (82)2 2630 4800 FAX: 2 2630 4801
Taiwan : IWAKI Pumps Taiwan Co., Ltd. TEL: (886)2 8227 6900 FAX: 2 8227 6818
Thailand : IWAKI (Thailand) Co.,Ltd. TEL: (66)2 322 2471 FAX: 2 322 2477
Vietnam : IWAKI Pumps Vietnam Co., Ltd. TEL: (84)613 933456 FAX: 613 933399

Caution for safety use:
Before use of pump, read instruction manual carefully to use the product correctly.

Legal attention related to export.

Our products and/or parts of products fall in the category of goods contained in control list of international regime for export control. Please be reminded that export license could be required when products are exported due to export control regulations of countries.

Actual pumps may differ from the photos. Specifications and dimensions are subject to change without prior notice. For further details please contact us.

