

## Maße / Dimensions Schieber Serie AT 200 mit Hydr-Zyl. Knife gate valve series AT 200 with hydraulic cylinder DN 350 - DN 1200

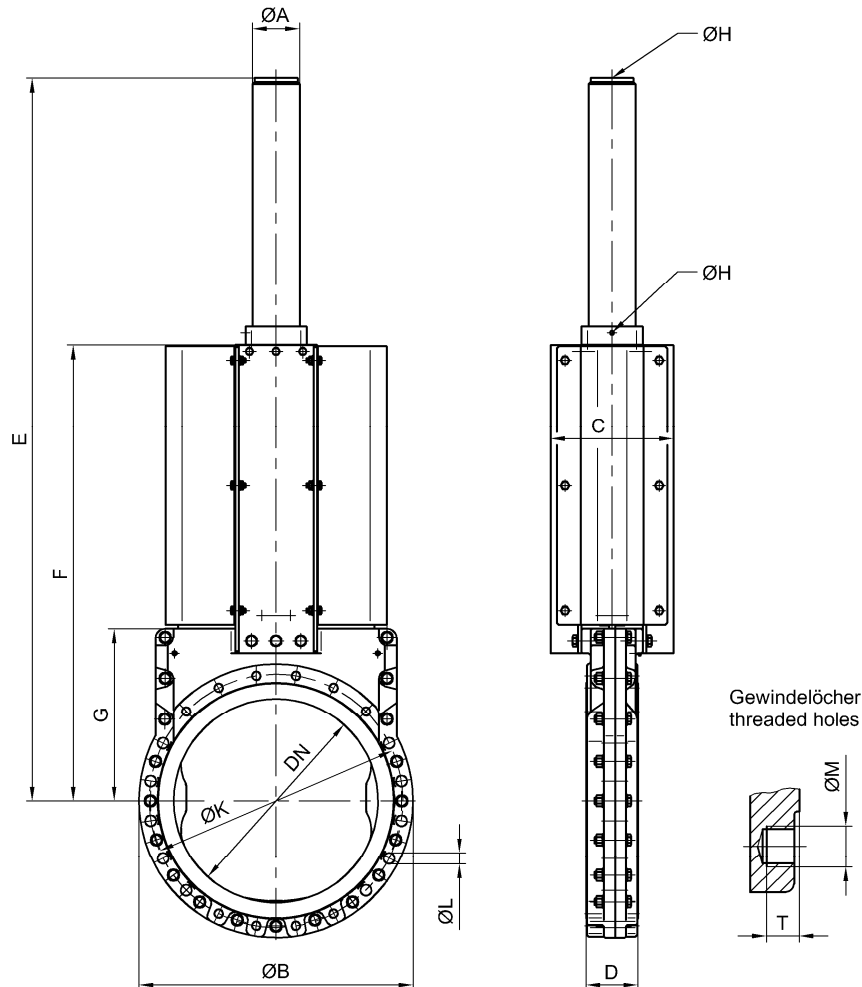

DN	NPS	Zyl.Ø.	ØA	ØB	C	D	E	F	G	ØH	ØK	ØL	ØM	T	kg
350	14"	80	95	505	300	78	1398	901	330	G1/4"	460	8xØ22	8xM20	18	154
400	16"	100	115	565	300	102	1491	937	366	G1/4"	515	8xØ27	8xM24	26	195
450	18"	100	115	615	300	114	1685	1082	390	G1/4"	565	10xØ27	10xM24	26	235
500	20"	100	115	670	300	127	1767	1113	421	G1/4"	620	10xØ27	10xM24	26	281
600	24"	125	150	780	330	154	2097	1316	510	G1/4"	725	10xØ30	10xM27	35	461
700	28"	125	150	895	380	165	2389	1507	615	G1/4"	840	12xØ30	12xM27	39	735
800	32"	125	150	1015	380	190	2674	1692	700	G1/4"	950	12xØ33	12xM30	49	743
900	36"	150	180	1115	380	203	3040	1958	850	G1/4"	1050	14xØ33	14xM30	43	1529
1000	40"	150	180	1230	380	216	3300	2118	900	G1/4"	1160	14xØ36	14xM33	45	1807
1200	48"	150	180	1455	500	254	3852	2470	1040	G1/4"	1380	16xØ39	14xM36	55	2554

Steuerdruck für Hydraulik-Zylinder / operating pressure for hydraulic cylinder: 120 bar

Max. Betriebsdruck:  
 Max. working pressure:

DN	Druck / pressure
350-400	6,0 bar
450-800	4,0 bar
900	3,0 bar
1000	2,5 bar
1200	2,0 bar

Änderungen vorbehalten  
 subject to changes