

Maße Processklappe Serie K17 Dimensions butterfly valve series K17 DN 350 – DN 500

Baulänge: EN 558-1 Reihe 20 (DIN 3202-K1)
 Kopfflansch: ISO 5211

Face to face dimension: EN 558-1 line 20 (DIN 3202-K1)
 Mounting plate: ISO 5211

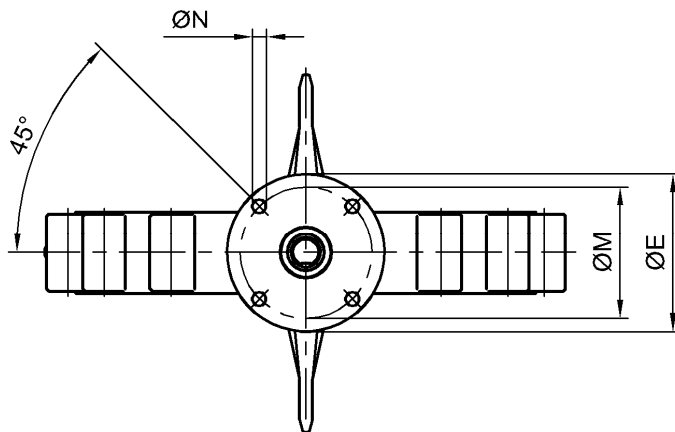
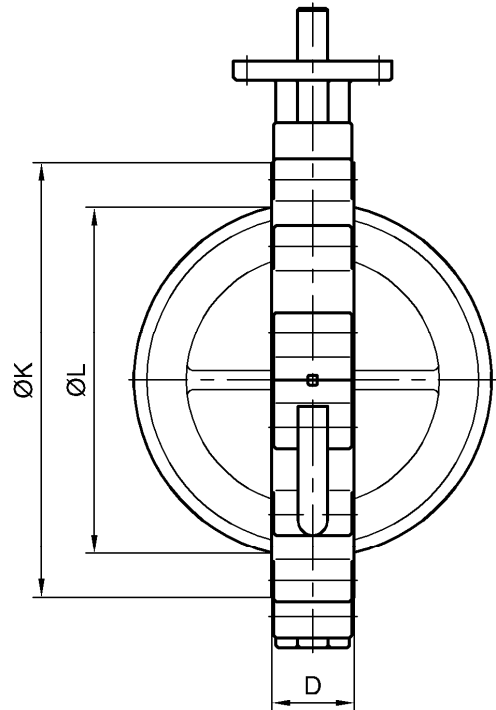
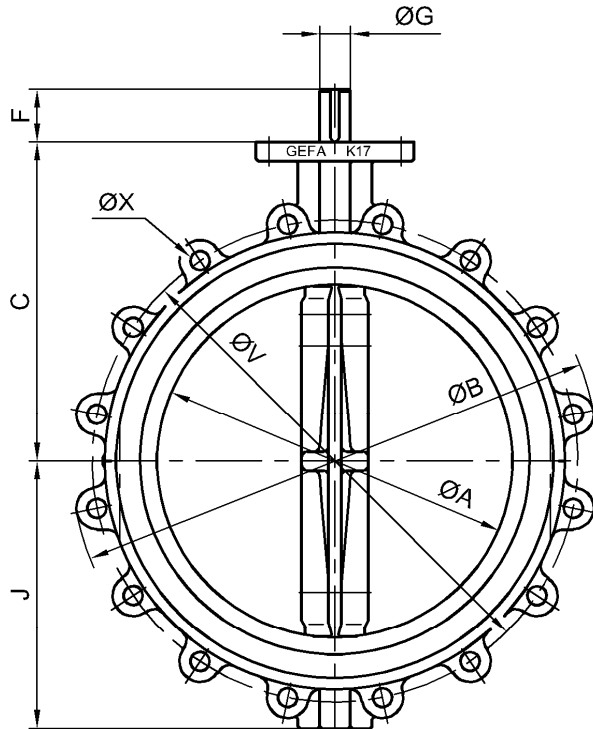

DN	NPS	PN10	
		ØV	ØX
350	14"	460	16 x M20
400	16"	515	16 x M24
450	18"	565	20 x M24
500	20"	620	20 x M24

ØK = Sitzring-Außendurchmesser
 Seat outside diameter

ØL = kleinster Flanschinnendurchmesser
 smallest inside diameter of flange

DN	NPS	ØA	ØB	C	D	ØE	F	ØG	J	ØK	ØL	Passfeder Key DIN 6885	Kopfflansch Mounting plate			kg
													ØM	ØN	ISO 5211	
350	14"	336	500	305	78	150	50	29	255	401	330	8 x 7	125	4 x Ø13	F12	54
400	16"	387	585	330	102	150	60	40	285	461	377	12 x 8	125	4 x Ø13	F12	82
450	18"	438	640	370	108*	210	60	40	320	518	428	12 x 8	165	4 x Ø22	F16	146
500	20"	488	685	403	127	203	60	50	352	573	475	14 x 9	165	4 x Ø22	F16	193

* Baulänge: GEFA Standard

Face to face dimension: GEFA standard

Änderungen vorbehalten
 subject to changes