

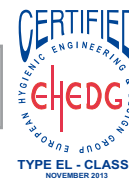

Hygienic Centrifugal pumps



CSA Series

CSA series pumps are designed, tested and approved to EHEDG (European Hygienic Engineering & Design Group) hygiene protocols and to US 3A standards. Used mainly in the foodstuffs and pharmaceutical industries, they fulfil the highest sanitary requirements.

The modular construction enables C.S.F. to provide the most suitable pump. Optimised performance and low NPSH requirements are integral to the design of CSA Series pumps.

Standard design

Open impeller.

Wetted parts in CF-3M 1.4404 / AISI 316L stainless steel, investment cast and electro-chemically polished.

Special internal finish to 0,8 micron Ra.

Adjustable stainless steel feet.

Flow rates up to 300 m³/h, heads up to 100 m (10 bar); low NPSH requirements.



Sanitary Self-Priming Pumps



n° 02 - 11 739

ASH series

ASH Series pumps are approved to the latest US 3A sanitary standards; ideal for systems where compliance to the most strict hygiene regulations is essential.

The ability of ASH pumps to repeatedly create a vacuum makes them ideal for applications where air or gas is entrained in the pumped liquid – Perfect for CIP scavenge and duties where the inlet pipework is only partially filled with fluid, including foaming products.

Manufactured for a wide range of requirements in the food, beverage and pharmaceutical process sector. This market leading design includes the latest technologies and construction materials.

Standard design

Wetted parts in CF-3M 1.4404 / AISI 316L stainless steel. Investment cast and electro-chemically polished.

Special internal finish 0,8 micron Ra.

Adjustable stainless steel feet.

Flow rates up to 40 m³/h, heads up max. 35 m (3,5 bar) (50 Hz).



CSA series

Closed coupled sanitary centrifugal pumps with open impeller and independent shaft support.

Suitable for motors in compliance with the following standards:
 IEC 34-1
 VDE 0530T1
 NF C51-111
 BS5000 PART 99
 NEMA NG1 PART. I

Greased lubricated bearings.
 Clamp design casing and seal. Easy disassembly, quick inspection, cleaning and maintenance. Rotation of the delivery port for optimised installation.

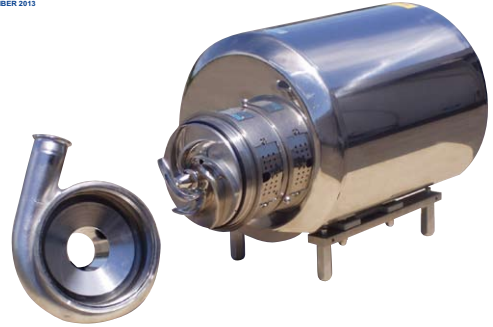

CSA SERIES CERTIFIED TO EHEDG / 3A

Seals:

Single external mechanical seal
 Double flushed (axial + radial) mechanical seal

CSA SERIES CERTIFIED TO 3A

Seals:

Protected, balanced and bi-directional internal mechanical seal with seats according to EN 12756, ISO 3069 standards.

Elastomers (certified to FDA - 3A - USPVI):

EPDM
 FLUOROCARBON - (FPM *DIN/ISO*), (FKM *ASTM*)
 P.T.F.E. (FEP)

Connections:

CLAMP
 DIN 11864
 Others on request

GENERAL DIAGRAMS

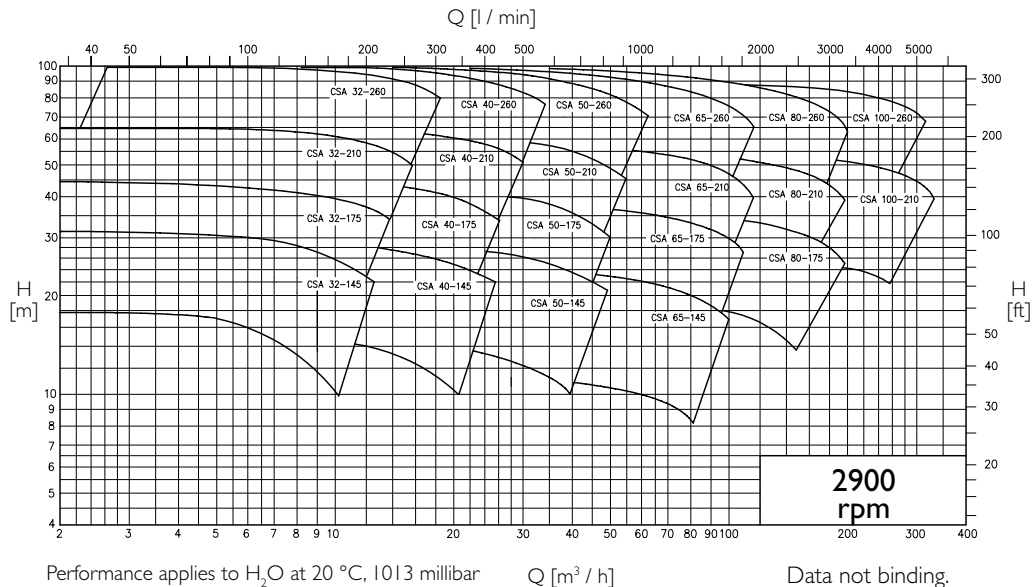
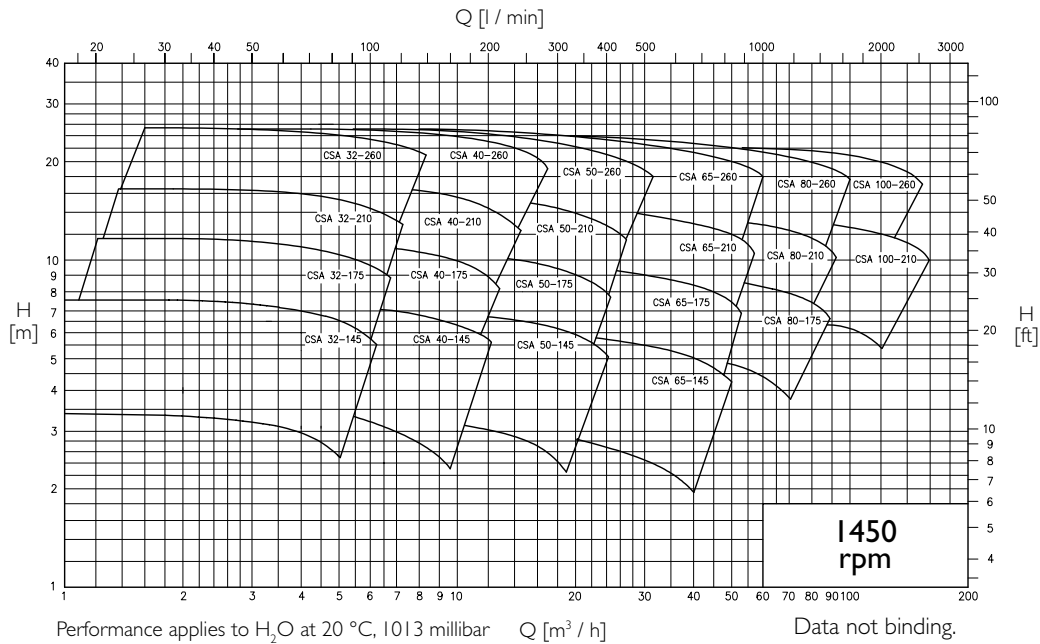

ASH series

Close coupled sanitary self-priming pumps with independent shaft support.

Suitable for motors in compliance with the following standards:
 IEC 34-1
 VDE 0530T1
 NF C51-111
 BS5000 PART 99
 NEMA NG1 PART. I



Greased lubricated bearings.
 Clamp design casing and seal. Easy disassembly, quick inspection, cleaning and maintenance.

Seals:

Single internal mechanical seal, protected, balanced and bi-directional, with seats according to EN 12756, ISO 3069.

Elastomers (certified to FDA - 3A - USP VI):

EPDM
 FLUOROCARBON - (FPM *DIN/ISO*), (FKM *ASTM*)
 P.T.F.E. (FEP)

Connections:

CLAMP
 DIN 11864
 Others on request



GENERAL DIAGRAMS

A 50 Hz

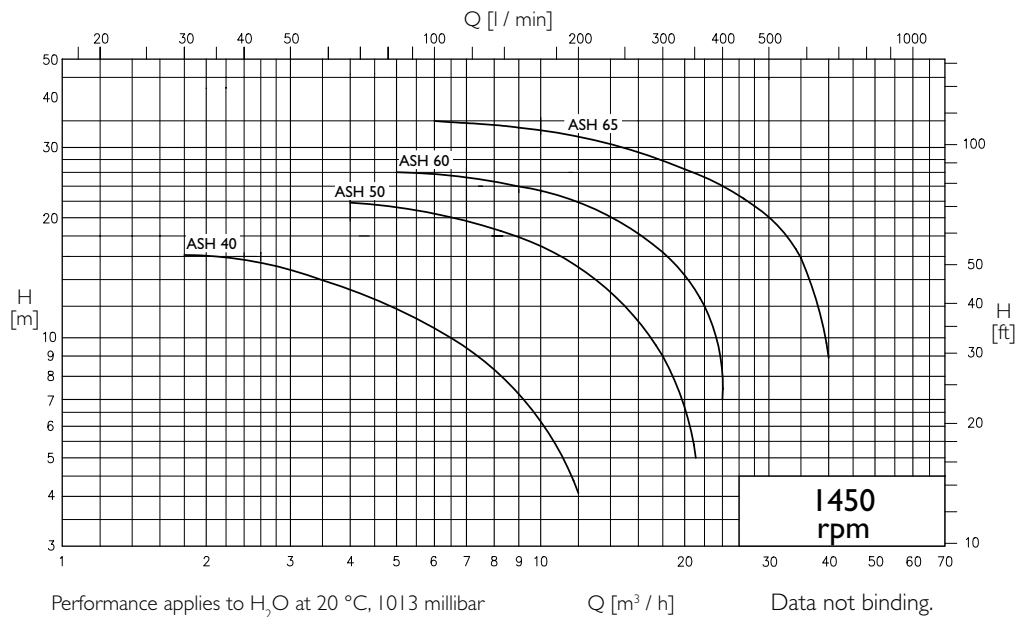

A 60 Hz

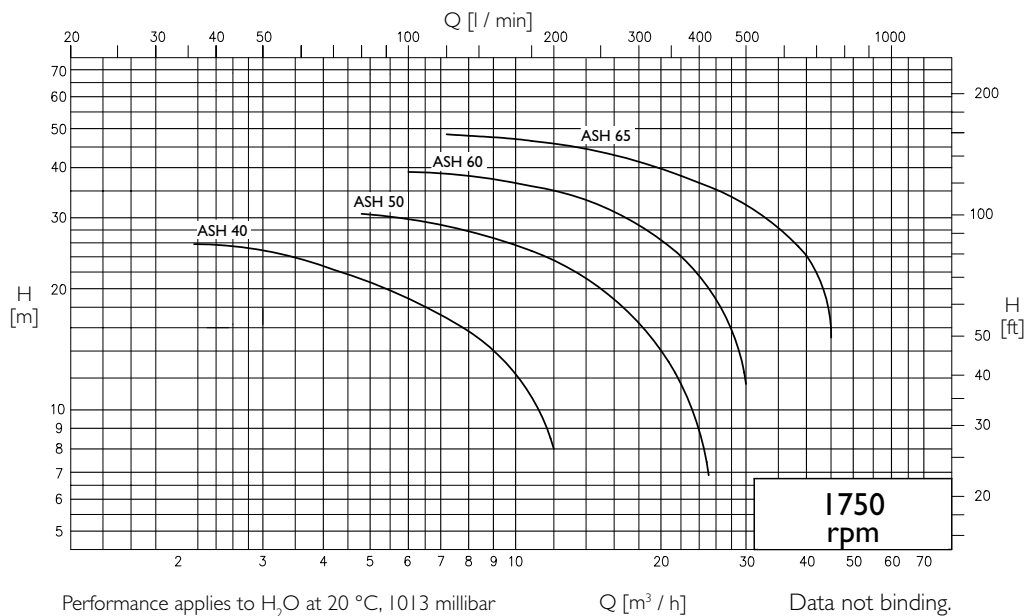

CSA OVERALL DIMENSIONS

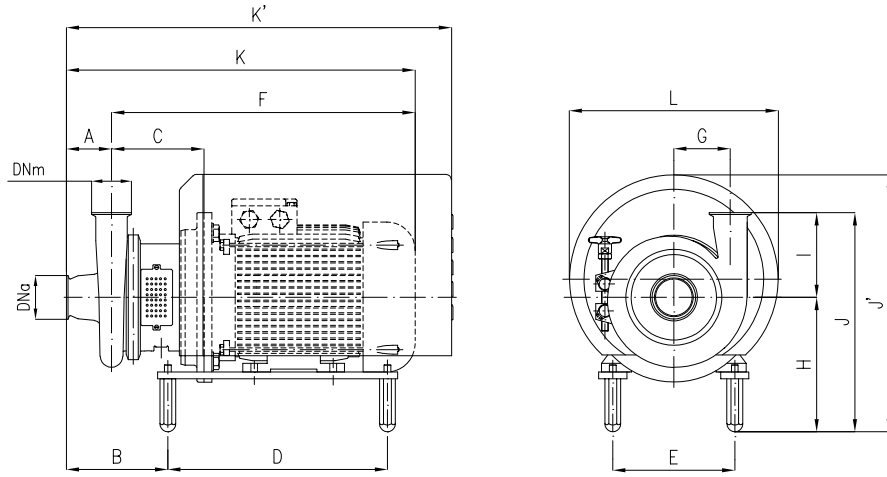

Dimensions not binding - DN = "Clamp" ISO 2852 connections, with standard IEC/EN motors

Pumps	IEC motors size:	DNa	DNm	A	B	C	D	E	F	G	H	K	K'	I	J	J'	L
CSA 32-145	80	1 1/2"	1 1/2"	80	166	138	254	125	372	85	220	452	566	148	368	384	298
	90				172			140	419		230	499			378	394	
	100				165	139	314	160	451		240	531	637		388	445	330
	112							190	473		230	553			378	435	
CSA 32-175	80	1 1/2"	1 1/2"	80	167	139	254	125	373	95	220	453	567	148	368	384	298
	90				173			140	420		230	500			378	394	
	100				159	140	314	160	452		240	532	637		388	445	330
	112							190	473		230	553			378	435	
CSA 32-210	80	1 1/2"	1 1/2"	80	167	139	254	125	373	110	230	453	567	168	398	402	298
	90				173			140	420		240	532			398	435	
	100				159	140	314	160	452		240	532	637		408	445	330
	112							190	473		230	553			398	435	
	132 S				177	161	389	216	534		255	614	680		423	477	370
	132 M							578	658		735	448			543	430	
CSA 32-260	160	2"	1 1/2"	90	241	206	460	254	684	140	260	534	601	168	428	465	330
	90				193	164	314	160	476			566	671			482	
	100							200	190		497	587	714		448		543
	112				211	185	389	216	558		648	714	448			543	
	132 S							602	693		769	448			543		430
	132 M				270	225	460	254	703		280	793	967		448	543	430
CSA 40-145	80	2"	2"	80	167	139	254	125	373	90	220	453	567	133	353	384	298
	90				173			140	420		230	501			363	394	
	100				159	140	314	160	452		240	532	637		373	445	330
	112							190	473		230	553			363	435	
CSA 40-175	80	2"	2"	80	168	141	254	125	375	95	220	455	569	150	370	384	298
	90				175			140	422		230	502			380	394	
	100				161	142	314	160	454		240	534	639		390	445	330
	112							190	475		230	555			380	435	
	132 S				180	164	389	216	537		255	617	682		405	477	370
	132 M							581	661		737	430			543	430	
160	243	208	460	254	686	280	766	937	430	543	430						
CSA 40-210	80	2"	2"	80	168	141	254	125	375	115	235	455	569	160	395	399	298
	90				175			140	422			240			534	400	
	100				161	142	314	160	454		240	534	639		395	440	330
	112							190	475		235	555			395	440	
	132 S				180	164	389	216	537		250	617	682		410	472	370
	132 M							581	661		737	440			543	430	
160	243	208	460	254	686	280	766	937	440	543	430						
CSA 40-260	90	2"	2"	100	217	163	254	140	444	145	260	544	611	172	432	440	298
	100				203	164	314	160	476			576	681			465	
	112				210			190	497		597	724	482		370		
	132 S				221	185	389	216	558		702	779				452	502
	132 M							602	658		724	477	637		420		
	160				280	225	460	254	703		280	803	978		477	637	420
180	195	600	279	785	305	885	1094	477	637	420							
CSA 50-145	80	2 1/2"	2"	80	169	141	254	125	374	95	220	454	569	139	359	384	298
	90				175			140	422		230	502			369	394	
	100				161	142	314	160	454		240	534	639		379	445	330
	112							190	475		230	555			369	435	
	132 S				180	164	389	216	537		255	617	682		394	477	370
	160							537	617		682	409			477	370	
180	243	208	460	254	686	280	766	937	434	543	430						
CSA 50-175	80	2 1/2"	2"	80	169	141	254	125	374	100	230	454	569	154	384	394	298
	90				175			140	422			240			534	394	
	100				161	142	314	160	454		240	534	639		384	435	330
	112							190	475		230	555			384	435	
	132 S				180	164	389	216	537		255	616	682		409	477	370
	132 M							581	661		737	434			543	430	
160	243	208	460	254	686	280	766	937	434	543	430						

CSA OVERALL DIMENSIONS

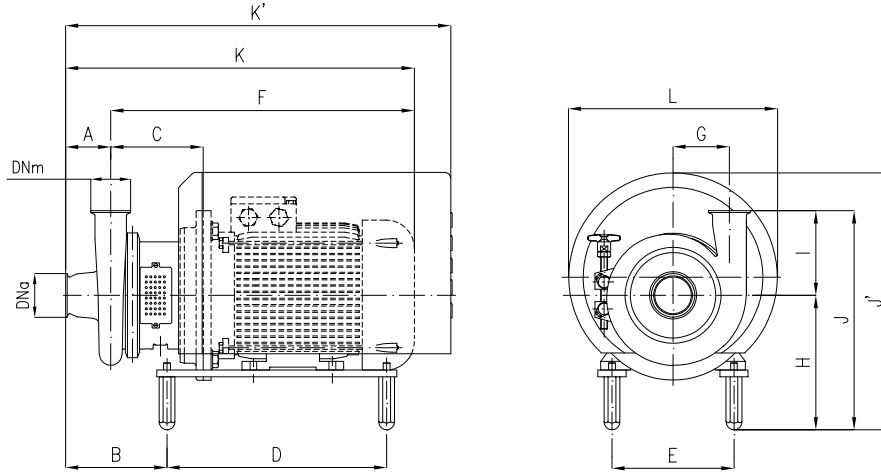

Dimensions not binding - DN = "Clamp" ISO 2852 connections, with standard IEC/EN motors

Pumps	IEC motors size:	DNa	DNm	A	B	C	D	E	F	G	H	K	K'	I	J	J'	L		
CSA 50-210	90	2 1/2"	2"	80	175	141	254	140	422	120	240	502	569	168	408	412	298		
	100				161	142	314	160	454			534	639			445	330		
	112				168			190	475			555							
	132 S				180	164	389	216	537			617	682			418	472	370	
	132 M								581			661	737						
	160				243	208	460	254	686			280	766			937	448	543	430
180	173	223	600	279	783	305	863	1072	473	637	420								
CSA 50-260	100	2 1/2"	2"	90	194	165	314	160	477	145	270	567	672	179	449	475	330		
	112				201			190	498			588							
	160				273	254	706	796	970			459	543					430	
	180				188	228	600	279	788			305	878					1087	484
CSA 65-145	80	3"	3"	79	172	145	254	125	379	112	245	458	572	138	383	409	298		
	90				178			140	426			505							
	100				164	146	314	160	458			537	642			393	477	370	
	112				171			190	479			558							
	132 S				183	168	389	216	541			255	620			685	418	543	430
	132 M								585				664			740			
160	246	212	460	254	690	280	769	940	418	543	430								
CSA 65-175	90	3"	3"	80	178	144	254	140	425	120	255	505	572	138	393	409	298		
	100				164	145	314	160	457			537	642					418	543
	112				171			190	478			558							
	132 S				183	167	389	216	540			280	769			940	418	543	430
	132 M								584				664			740			
	160				246	211	460	254	689			305	864			1073	443	637	420
180	174	224	600	279	784														
CSA 65-210	90	3"	3"	90	212	168	254	140	449	135	265	539	605	158	423	470	330		
	100				198	169	314	160	481			571	676					438	543
	112				205			190	502			592							
	160				276	460	254	709	280			799	974			463	637	420	
	180				191	231	600	279	791			305	881			1090	463	637	420
CSA 65-260	100	3"	3"	100	207	168	314	160	480	155	285	580	685	193	478	507	370		
	112				214			190	501			601							
	132 S				226	190	389	216	563			285	663			728	498	637	420
	132 M								607				707			783			
	160				285	230	460	254	708			305	808			983	548	430	
	180				200	230	600	279	790				890			1099	498	637	420
CSA 80-175	100	4"	3"	100	231	174	315	160	486	139	275	586	691	164	439	480	330		
	112				220			190	507			607							
	132 S				231	195	389	216	568			275	668			734	444	543	430
	160				291	236	460	254	714			280	814			989			
	180				206	236	600	279	796			305	896			1105	469	637	420
CSA 80-210	100	4"	3"	100	210	171	314	160	483	145	285	583	688	164	449	490	330		
	112				217			190	504			604							
	132 S				229	193	389	216	566			285	666			731	469	637	420
	160				288	233	460	254	711				811			986			
	180				203	233	600	279	793			305	893			1102	469	637	420
CSA 80-260	100	4"	3"	100	210	171	314	160	483	165	300	583	688	209	509	505	330		
	112				217			190	504			604							
	132 S				229	193	389	216	566			300	666			731	522	370	
	132 M								610				710			786			
160	288	233	460	254	711		811	986	563	430									
CSA 100-210	100	5"	4"	111	246	200	389	216	573	161	305	683	750	214	519	527	370		
	132 S				221	240	600	279	800			911	1120					634	420
	180				246	195	389	216	612				727			803	547	370	
CSA 100-260	160	5"	4"	115	305	235	600	254	713	186	325	828	1004	216	541	588	430		
	132 S				246			195	389			216	612						727
	180				305	235	600	279	795				910			1118	657	420	

ASH OVERALL DIMENSIONS

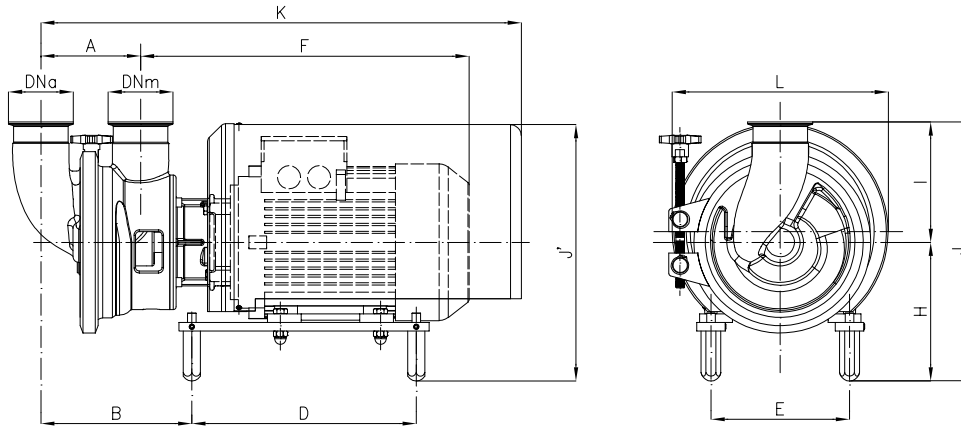

Dimensions not binding - DN = "Clamp" ISO 2852 connections, with standard IEC/EN motors

Pumps	1450 r.p.m.	kW	DNa	DNm	A	B	D	E	F	H	K	I	J	J'	L
ASH 40		1,1	1" 1/2	1" 1/2	90,5	183	245	140	410	207	551	139	346	354	239
	1,5	148,5				314	160	433	217	617	356		422	330	
	2,2	176,5				314	160	432	217	645	366		422	330	
ASH 50	2,2	183,5	190	453	230		378	435							
ASH 60	4	2"	2"	118	211	314	190	460	229	672	149	398	434	330	
	ASH 65			5,5	139	215	390	216	512	249		749	169	418	472
ASH 65	5,5	3"	3"	139	215	390	216	512	249	749	169	418	472	372	
	7,5				266	460	254	650	280	914		449	544	432	
	15														



C.S.F. Inox S.p.A. Strada per Bibbiano, 7 - 42027 Montecchio E. (RE) - ITALY EU
 Ph +39.0522.869911 ra. - Fx +39.0522.865454 / 866758 - csfitalia@csf.it - www.csf.it

Export Department • Commercial Étranger • Comercial Extranjero
 Ph +39.0522.869922 - Fx +39.0522.869841 - csfexport@csf.it - www.csf.it

All the instructions, data and representations (in whatever way executed) listed in this publication are indicative and do not binding. C.S.F. does not stand surety or undertake any obligation for the utilisation of this document and for the information contained. In particular, it does not guarantee against omissions or errors of the data and drawings here indicated.
 Notice that the technical specifications, information and representations in this document are merely indicative and approximate. C.S.F. INOX reserves the right at any moment and without notice to modify the data, drawings and information indicated in this document.