

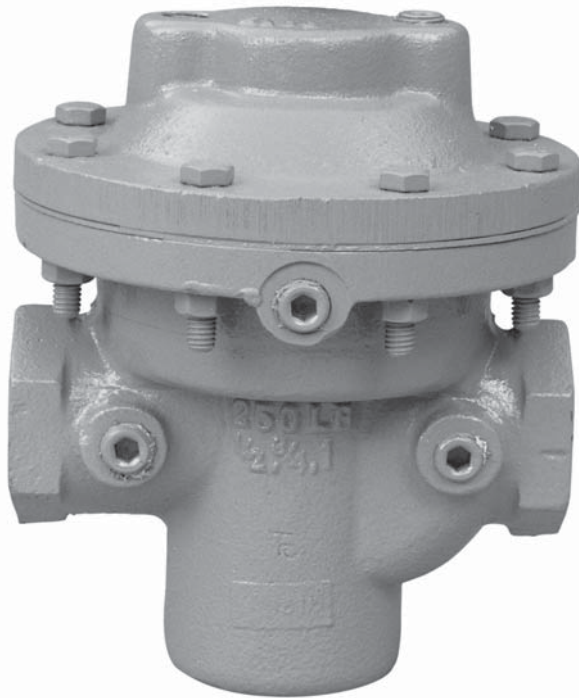

ISO Registered Company



MODEL DA4

### APPLICATIONS

“DO-ALL” concept allows application of all types of clean fluids. Designed primarily as a gaseous service valve, can be applied in liquid service applications where excessive cavitation or flashing is absent. Excellent for atmospheric industrial gases – GN<sub>2</sub>, GOX, Ar, He, H<sub>2</sub>, CO<sub>2</sub> – as well as a natural gas regulator. Used as a utilities – air, oil, water, steam – regulator. Corrosive and non-corrosive chemical services – gas or liquid – are possible with broad materials range.

### CAUTION

In the event of diaphragm failure, the process fluid will mix with the loading fluid.

## MODEL DA4

(FORMERLY DA3 AND DA4)

DO-ALL SERIES IV

PRESSURE REDUCING REGULATOR

PRESSURE LOADED DIAPHRAGM:

1/2" – 4" (DN15 – 100)

Model DA4 is high performance, pressure loaded diaphragm-type, flow-to-open pressure reducing regulator. Design includes an internal pressure balancing piston-cylinder that provides high flow capacity and high pressure drop capability. The internal trim design allows the same basic unit to cover a broad range of pressure settings. Performance meets or exceeds that of competitive pressure loaded or pilot-operated designs. The DA4 regulator is applied primarily in clean gaseous service, but may also be applied as a liquid or steam valve. Truly a “DO-ALL” pressure regulator.

### FEATURES

- Versatile:** Five basic materials and multiple trim material combinations to select from. Multiple methods of pressure loading.
- Tight Shutoff:** Multiple composition materials provide Class IV or VI inboard leakage rates. Designed as a soft-seated valve.
- Capacity:** Highest in the industry. Allows smaller body sizes than competitors in majority of applications.
- Droop:** Highly accurate outlet pressure control, due to absence of range spring in design, provides almost zero “droop effect”.
- Pressure Drop:** One of highest in the industry when coupled with high flow capacity.
- Trim Design:** “DO-ALL” trim design provides FTO and pressure balancing for higher inlet pressure. Results in unmatched sensitivity and stability. Internals are cage-contained within easily removable quick change trim.
- Rangeability:** Basic valve gives outstanding rangeability due to close tolerances, balanced trim, and a broad range of elastomeric and metallic diaphragms and soft seats. Can be as high as 2000:1.
- Heavy-Duty Guiding:** Both top and bottom guided to maintain stability and increased diaphragm life.
- Failure Position:** Fails closed on loss of loading pressure.  
Fails open on loss of P<sub>1</sub> or P<sub>2</sub> pressures with loading pressure yet applied.

## STANDARD / GENERAL SPECIFICATIONS

### Body / Cover Dome Materials

DI/DI	SST/DI	HC/SST *
CS/DI	SST/CS	Dup SST/CS
CS/CS	SST/SST	Dup SST/SST
BRZ/BRZ	HC/CS *	Dup SST/DupSST
BRZ/DI		

\* Through 2" (DN50) body size only.

DI = Ductile Iron CS = Carbon Steel BRZ = Bronze  
 SST = Stainless Steel HC = Hastelloy "C"  
 Dup SST= Super Duplex SST

### Body Sizes

1/2", 3/4", 1", 1-1/4", 1-1/2", 2", 2-1/2", 3", 4".  
 (DN15, 20, 25, 32, 40, 50, 65, 80, 100)

### End Connections

**Standard:** Female NPT (screwed).  
**ASME Flanged:** 125#, 150#, 250#, 300#, 600#;  
**DIN Flanged:** PN16, PN25, PN40;  
 (Integral Flanged Body unless listed under Opt.-30)  
**Opt-31:** British Standard Pipe Threads.  
**Opt-32:** Schedule 80 Extended Pipe Nipples.  
**Opt-34:** 14" Face to Face Flange Dimension.  
**Opt-41:** Extension Tube Ends.

### Max. Useable Cv

Body Size		Diaphragm		Body Size		Diaphragm	
		Comp. Cv	Metal Cv			Comp. Cv	Metal Cv
in	(DN)			in	(DN)		
1/2"	(15)	3.6	3.5	2"	(50)	54	12
3/4"	(20)	7.2	3.5	2-1/2"	(65)	81	N/A
1"	(25)	13.5	3.5	3"	(80)	108	N/A
1-1/4"	(32)	20.7	6.0	4"	(100)	198	N/A
1-1/2"	(40)	27.0	6.0				

See Table DAG-6 for Wide Open Cv Limits.

N/A = Not Available.

**METRIC CONVERSION FACTOR: Cv / 1.16 = kv**

### Inlet Pressure Range

Operating: 10–3705 psig (.68 – 255 Barg).

See Tables DAG-1A through -1H for design P vs. T limits.

### Outlet Pressure Range

1/2" – 1" (DN15–25) ...2.0" WC– 1500 psig (103 Barg)  
 1-1/4" – 2" (DN32–50) ..2.0" WC– 1250psig(86.1 Barg)  
 2-1/2" – 4" (DN65–100) .2.0" WC– 600 psig (55.2 Barg)

Function of diaphragm material and diaphragm construction. See Table 1.

### Pressure Drop Limits

5–1500 psid (.34 – 103.4 Bard)

Function of service fluid, base trim material, diaphragm and dynamicseal design. See Table 1 and Table DAG-2, DAG-3& DAG-4.

### Temperature Range

-425° to +400°F (-254° to +204° C)

Limited by body/cover dome/diaphragm material combinations, and by elastomeric seat, static seal, dynamic seal – materials. See Tables DAG-1A through -1H and Table DAG-5.

Alternate "CS" Mat'l - Steel - ASTM A352 Gr. LCC -  
 Minimum temperature -50 °F (-46 °C).

### Inboard Leakage Rates

See Table DAG-10

### Lower Piston Spring

(Formerly Model DA3): No lower piston spring;  $P_2 = P_{Load}$   
 Lower piston spring required;  $P_2 < P_{Load}$   
 See Table DAG-9 for available spring ranges.

**NOTE:** Use a lower piston spring with the following applications:

1. When using a metal diaphragm.
2. Pilot loaded.
3. When decaying inlet may reach 0 psig.

### Optional Constructions

<p><u>Opt-30:</u> Weld-on Flanges  <u>Opt-31:</u> BSP End Conns.  <u>Opt-32:</u> Ext. Pipe Nipples  <u>Opt-34:</u> Special 14" F to F  <u>Opt-40:</u> NACE Const.  <u>Opt-41:</u> Ext. Tube Ends  <u>Opt-55:</u> Oxygen Cleaned</p>	<p><u>Opt-56:</u> Special Cleaned  <u>Opt-57:</u> Chlorine Cleaned  <u>Opt-81:</u> Full Diaph Support  <u>Opt-85:</u> Extra Set Pressure Taps  <u>Opt-95:</u> Epoxy Paint  <u>Opt-95OS:</u> Epoxy Paint</p>
---	---

### ABBREVIATIONS

FK = Fluorosilicone	NBR = Buna-N	PTFE = Polytetrafluoroethylene
FKM = Fluorocarbon	RTFE = Brz-fill TFE	V-TFE = Virgin TFE
EPR = Ethylene Propylene	GF-TFE = Glass-fill TFE	CTFE = Chlorotrifluoroethylene
BC = Neoprene	PA = PolyAll	3-ply (PTFE+FKM+PTFE)

## MATERIAL SPECIFICATIONS

### Body

DI – ASTM A395  
CS – ASTM A216, Grade WCB.  
     Alternate ASTM A352 Grade LCC  
BRZ – ASTM B62, Alloy 83600,  
SST – ASTM A351, Grade CF3M.  
     Alternate ASTM A995/A995M7 Gr. 6A  
HC – ASTM A494, Grade CW-12 MW.

See DAG-1A through DAG-1H for material specs.

### Cover Dome

DI – ASTM A395  
CS – ASTM A216, Grade WCB.  
     Alternate ASTM A352 Grade LCC  
BRZ – ASTM B62, Alloy 83600,  
SST – ASTM A351, Grade CF3M  
     Alternate ASTM A995/A995M7 Gr. 6A

### Metallic Trim \*

Plug, Cage, Piston: 17-4PH SST, 316L SST,  
 Nickel-Copper Alloy (Monel<sup>†</sup>),  
 See Table 2.

### Diaphragm \*

Elastomeric – BC, EPR, FKM, FK, NBR, FKM+TFE,  
 3-ply (PTFE+FKM+PTFE).  
Metallic – Be-Cu. (only 1/2" - 2" sizes)

### Seat \*

PolyAll, V-TFE, GF-TFE, CTFE, BC, NBR, FKM

### Static Seals (See Fig. DAG-F1) \*

RTFE, NBR, FKM, FK, EPR - o-ring  
 SST/TFE (1/2"-2") (DN15-50) sizes,  
 V-TFE (2-1/2"-4") (DN65-100) sizes.

### Dynamic Seals (See Fig. DAG-F1) \*

Type OR - NBR, FKM, FK, EPR - o-ring seal.  
Type UC – V-TFE u-cup seal w/316L SST energizer  
     – V-TFE u-cup seal w/ Elgiloy energizer  
Type CW – TFE cap seal with o-ring energizer  
     (o-ring material same as static seal)  
     and GF-TFE wiper backup seal.  
Type PW – GF-TFE piston ring assembly seal with  
     17-7PH SST energizer; and GF-TFE  
     wiper backup seal.

### Painting

Standard: All non-corrosion resistant portions to be painted  
 with corrosion resistant epoxy paint per Cashco Spec  
 #S-1606.

Alternate: See Opt-95or Opt-95OS.

\* See Product Coder for acceptable combinations.

† Hastelloy<sup>®</sup>, Monel<sup>™</sup> and Inconel<sup>®</sup> are registered trade  
 names:

Hastelloy<sup>®</sup> is a mark owned by Stelite Div., Cabot Corp.

Monel<sup>™</sup> is a mark owned by International Nickel Co.

Inconel<sup>®</sup> is a mark owned by International Nickel Co.

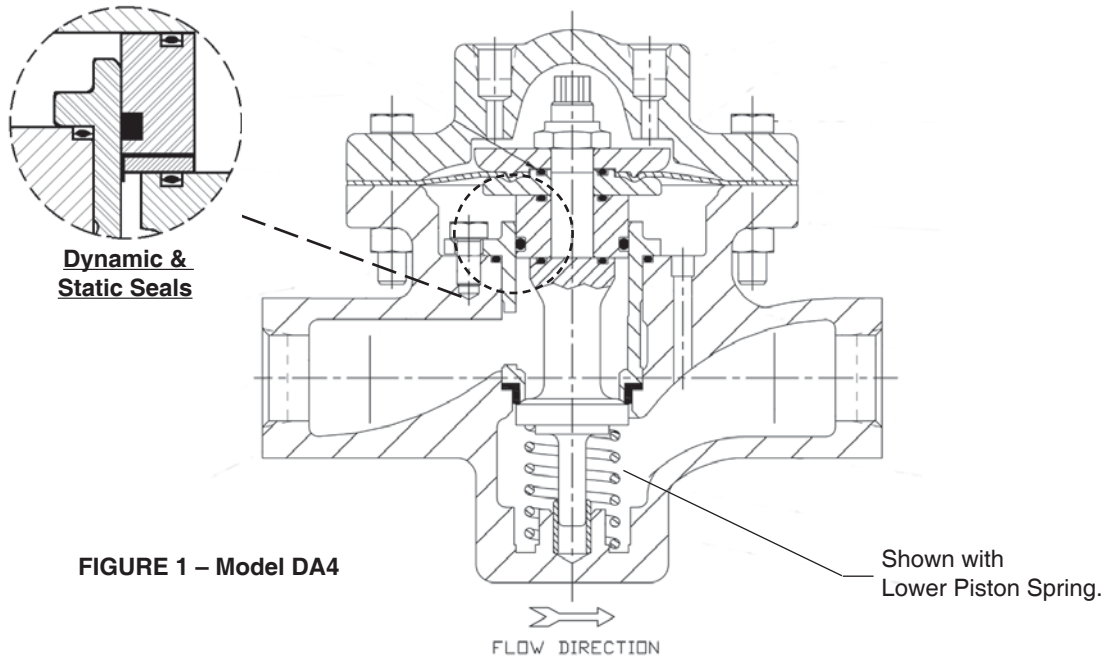

**OPTION SPECIFICATIONS**

**OPT-30: WELDED FLANGED CONNECTIONS.** CS, SST or HC body materials only. 1/2" – 1-1/2" (DN15–40) body sizes only (no 1-1/4" (DN32) size). Welded-on flange of same general chemistry as body.

Weld-On Flanges		
Sizes	Body Material	ASME Pressure Class
1/2" - 3/4"	CS, SST	150, 300, 600
1"	CS, SST	600
1", 1-1/2"- 2"	HC	150, 300
Sizes	Body Material	ISO Pressure Class
DN15-50	CS, SST	PN40 RF
DN65-100	CS, SST	PN16, 25, 40 RF

**NOTES:** 1. The body P vs. T ratings are the limiting variables for flanged end connections, unless further restricted by ASME B16.5.  
2. No post-weld stress relieving performed.

**OPT-31: BSP END CONNECTIONS.** British Standard Pipe threads per ISO 7/1; used as an alternate to NPT ends. 1/2" – 2" (DN15–50) sizes only.

**OPT-32: EXTENDED PIPE NIPPLES.** Sch. 80 extension pipe nipples available for CS and SST bodies; for body sizes 1/2" – 2" (DN15–50) only.

**OPT-34: SPECIAL 14" FACE TO FACE DIMENSION FOR FLANGED END CONNECTIONS.** Sizes 1/2" - 1" & 1-1/2" only. See Opt-30 for standard face to face dimension.

**OPT-40: NACE CONSTRUCTION.** Internal wetted portions meet NACE Std. MR0175 for application in sour gas/crude service. Exterior of unit to not be directly buried, insulated, or otherwise denied direct atmospheric exposure. CS/CS, LCC/LCC, LCC/SST, SST/CS, or SST/SST body/cover dome materials only. 316L SST trim material only. ELG/TFE U-cup dynamic seals. Available in all end connections. All welded portions heat treated to stress relieve weldments. The lower spring in the Model DA4 is constructed of Inconel<sup>†</sup>.

**OPT-41: EXTENDED TUBE END CONN.** SST body material only. Body sizes 1/2" - 1" (DN15–25), 1-1/2" - 2" only. SST extension tubes are welded to body, ending in tube diameters with 0.065 inch (1.65 mm) wall thickness, NOT FOR HIGH PURITY REQUIREMENTS.

**OPT-55: SPECIAL CLEANING - GOX.** BRZ or SST body materials only. Cleaning, assembly and packaging per Cashco Spec #S-1134, making unit suitable for Oxygen Service. **NOTE: Design Pressure Rating shall not exceed 375 psig (25.8 Barg) when body/topworks material is SST and process medium is oxygen.**

**OPT-56: SPECIAL CLEANING.** Cleaning per Cashco Spec. No. S-1542 for all body/cover dome materials. Higher cleaning level than std. commercial cleaning. NOT suitable for Oxygen Service.

**OPT-57: SPECIAL CLEANING-Cl<sub>2</sub>.** CS, SST, or HC body materials only. cleaning per Cashco Spec. No. S-1589. For chlorine gas/liquid service.

**OPT-81: FULL DIAPHRAGM SUPPORT CONSTRUCTION.** Incorporates top and bottom diaphragm support that allows reaching higher fluid pressures on the underside and topside of diaphragm. Sizes 1/2"-2" (DN15 - 50) only. See Table 1.

**OPT-85: PRESSURE TAPS.** Provides second set of inlet and outlet 1/4" (DN8) - FNPT taps with plugs (same basic material as body) on backside of body. Includes second external sensing port tap. See page 18 for details on tap location for both STD. and Opt -85. **NOTE:** Not available for HC body.

**OPT-95: EPOXY PAINT.** Special epoxy painting of all non-corrosion resistant external surfaces per Cashco Spec #S-1547. Utilized in harsh atmospheric conditions.

**OPT-95OS: EPOXY PAINT.** Special epoxy painting of all non-corrosion resistant external surfaces per Cashco Spec #S-1687. Utilized in OFFSHORE atmospheric conditions.



**TABLE DAG-1A  
DI – DUCTILE IRON  
BODY / TOPWORKS MATERIAL SPECIFICATIONS**

**DESIGN PRESSURE vs. TEMPERATURE vs. END CONNECTION RATINGS  
(To ASME B16.1 for Flanged and B16.4 for NPT Connections per Cast Iron Rating)**

Material Specifications (Body / Topworks)		End Connection – Inlet & Outlet					
Description (Abbr.)	ASTM No.	Temperature °F	Working Pressure – psig				
			End Connection – Pressure Class				
			NPT	125# FF	250# RF		
DI/DI (Note 1)	A395/ A395	-20° to +150°	400	200	500		
		200°	370	190	460		
		225°	355	180	440		
		250°	340	175	415		
		300°	310	165	375		
		350°	300	150	335		
		400°	250	140	290		
		406°	250	140	290		
			400 WOG, 250 S	225 WOG, 125 S	400 WOG, 250 S		
				Working Pressure – Barg			
				End Connection – Pressure Class			
				NPT	125# FF	250# RF	
				-29° to +65°	27.6	13.8	34 .5
				107	24.5	12.5	30.2
				120°	23.4	12.1	28.7
		150°	21.2	11.2	25.7		
		177°	19.2	10.6	23.8		
		204°	17.5	9.6	20.3		

**NOTE 1:** Whenever body and topworks materials are mixed, the P vs. T ratings that should be applied are those which are lowest of the two materials.

**Example:** CS body, DI topworks; NPT end connections, 200°F temperature.

Because the topworks is not “end flanged”, use the DI limits of "400 PSIG CWP 370/200F" from above to compare to CS limits from DAG-1C values. The DI limits are lower, so ratings from DAG-1A MUST be used as the limits.

**NOTE 2:** Unless stated otherwise, design pressure is Maximum Allowable Working Pressure (MAWP) for Inlet and Outlet.

**TABLE DAG-1B  
BRZ – BRONZE  
BODY / TOPWORKS MATERIAL SPECIFICATIONS**

**DESIGN PRESSURE vs. TEMPERATURE vs. END CONNECTION RATINGS  
(Per ASME B16.24 for Flanged and B16.15 for NPT Connections)**

Material Specifications (Body / Topworks)		End Connection – Inlet & Outlet (Note 2)				
Description (Abbr.)	ASTM No.	Temperature °F	Working Pressure –psig			
			End Connection – Pressure Class			
			NPT	150# FF	300# FF	
BRZ/BRZ (Note 1)	B62, Alloy C83600/B62, Alloy C83600	-325° to +150° *	700 † / 500	225	500	
		175°	390	220	480	
		200°	385	210	465	
		225°	375	205	445	
		250°	365	195	425	
		300°	335	180	390	
		350°	300	165	350	
		400°	250	150	315	
		406°	250	150	315	
		Temperature °C	Working Pressure – Barg			
			End Connection – Pressure Class			
			NPT	150# FF	300# FF	
			-198° to +65° *	48.3 † / 34.5	15.5	34.5
			107°	25.8	14.0	30.8
			120°	25.1	13.5	29.5
			150°	23.0	12.4	26.8
			177°	20.4	11.3	24.0
			204°	17.8	10.3	21.4

**NOTE 1:** Whenever body and topworks materials are mixed, the P vs. T ratings that should be applied are those which are lowest of the two materials.

**Example:** BRZ body, DI topworks; NPT end connections, ambient temperature.  
Because the topworks is not “end flanged”, use the DI limits of “400 PSIG CWP 370/200F” from DAG-1A to compare to above DAG-1B values. The DI limits are lower, so ratings from DAG-1A MUST be used as the limits.

**NOTE 2:** Unless stated otherwise, design pressure is Maximum Allowable Working Pressure (MAWP) for Inlet and Outlet.

† **For Pressure Reducing Regulator DA4** use 700 psig (48.2 Barg) inlet / 500 psig (34.4 Barg) outlet at 150°F as maximum limits.

\* See Minimum Temperature Ratings Table below.

**DESIGN PRESSURE RATING  
AT MIN. TEMPERATURE**

Regulator Function	Material Specifications (Body / Topworks - Connections) Description (Abbr.)	Pressure at Min. Temperature
Pressure Reducing	BRZ/BRZ - NPT	Inlet - 700 psig CWP to -325°F (-198°C)
		Outlet - 500 psig CWP to -325°F (-198°C)
	SST/SST - NPT, BSP, Ext. Nipples, Tube Ends and 600# Flgs	Inlet - 1440 psig CWP to -425°F (-254°C)
		Outlet - 625 psig CWP to -425°F (-254°C)

### Body Material Specifications

**Cast Steel** A216 Gr. WCB or Steel Weldment A216 Gr. WCB w/ forged flanges A105

**Alternate Material:** Cast Steel A352 Gr. LCC or Steel Weldment A352 Gr. LCC w/ forged flanges A350 Gr. LF6 Class 2

### Topworks Material Specifications

**Cast Steel** A216 Gr. WCB

**Alternate Material:** Cast Steel A352 Gr. LCC

### DESIGN PRESSURE vs. TEMPERATURE vs. END CONNECTION RATINGS

(Per ASME B16.5 and B16.34) See NOTE 1

<b>TABLE DAG-1C</b>					
<b>DESIGN INLET PRESSURE FOR DA4</b>					
<b>in PSIG (BARG)</b>					
<b>CONSTRUCTION</b>	<b>END CONNECTIONS</b>				
	<b>STD DIAPHRAGM</b>	<b>ALL</b>			<b>Opt-81 (Full Support Diaph.) DA4</b>
<b>DESIGN TEMP. RANGE: Deg F (Deg C) **</b>	<b>NPT, BSP</b>	<b>600#, EXTD NIPP</b>	<b>150#</b>	<b>300#</b>	<b>NPT, BSP</b>
-20 to +100 (-29 to +38)	1480 (102.1)	1480 (102.1)	285 (19.6)	740 (51.1)	3705 (255.3)
-20 to +200 (-29 to +93)	1360 (94.2)	1360 (94.2)	260 (17.9)	680 (47.1)	3375 (235.5)
-20 to +300 (-29 to +149)	1310 (90.3)	1310 (90.3)	230 (15.8)	655 (45.1)	3280 (225.6)
-20 to +400 (-29 to +204)	1265 (87.3)	1265 (87.3)	200 (13.7)	635 (43.6)	3170 (218.3)

\*\* Alternate Mat'l: ASTM 352 Gr. LCC Minimum Temperature -50 °F (-46 °C).

<b>TABLE DAG-1D</b>				
<b>DESIGN OUTLET PRESSURE FOR DA4</b>				
<b>in PSIG (BARG)</b>				
<b>CONSTRUCTION</b>	<b>END CONNECTIONS</b>			
	<b>STD DIAPHRAGM</b>	<b>ALL</b>		<b>Opt-81 (Full Support Diaph.) DA4</b>
<b>DESIGN TEMP. RANGE: Deg F (Deg C) **</b>	<b>NPT, BSP, 600#, EXTD NIPP</b>	<b>150#</b>	<b>300#</b>	<b>NPT, BSP, 600#, EXTD NIPP</b>
-20 to +100 (-29 to +38)	750 (51.7)	285 (19.6)	740 (51.1)	1350 (93.0)
-20 to +200 (-29 to +93)	680 (47.1)	260 (17.9)	680 (47.1)	1350 (93.0)
-20 to +300 (-29 to +149)	655 (45.1)	230 (15.8)	655 (45.1)	1310 (90.3)
-20 to +400 (-29 to +204)	635 (43.6)	200 (13.7)	635 (43.8)	1265 (87.3)

\*\* Alternate Mat'l: ASTM 352 Gr. LCC Minimum Temperature -50 °F (-46 °C).

**NOTE 1:** These pressure ratings may be further derated by limitations thru the Pressure Equipment Directive (97/23/EC-May '97). Whenever body and topworks are mixed, the P vs. T ratings that should be applied are those which are lowest for the two materials.

**Example:** 600 lb. RF flanged steel body, full support diaphragm construction, at 200 deg F maximum temp would have a preliminary inlet to 3375 psig and outlet to 1350 psig, but if fitted with a ductile iron topworks pressure rating is only 370 psig. Must derate both the inlet and outlet to 370 psig. (Note: Topworks pressure rating, same as NPT design outlet pressure rating for the selected topworks material and diaphragm type.



### Body Material Specifications

**Cast Stainless Steel** A351 Gr.CF3M or Stainless Steel Weldment A315 Gr. CF3M w/ forged flanges A182 Gr. F 316L

**Alternate Material:** Super Duplex SST A995/A995M Gr. 6A

### Topworks Material Specifications

**Cast Stainless Steel** A351 Gr.CF3M

**Alternate Material:** Super Duplex SST A995/A995M Gr. 6A

**DESIGN PRESSURE vs. TEMPERATURE vs. END CONNECTION RATINGS**  
(Per ASME B16.5 and B16.34) See NOTE 1

<b>TABLE DAG-1E</b>					
<b>DESIGN INLET PRESSURE FOR DA4</b>					
<b>in PSIG (BARG)</b>					
<b>CONSTRUCTION</b> *	<b>END CONNECTIONS</b>				
	<b>STD</b> <b>DIAPHRAGM</b>	<b>ALL</b>			<b>Opt-81 (Full Support Diaph.)</b> <b>DA4</b>
<b>DESIGN TEMP.</b> <b>RANGE: Deg F</b> <b>(Deg C)</b>	<b>NPT, BSP</b>	<b>600#, EXTD</b> <b>NIPP, TUBE</b>	<b>150#</b>	<b>300#</b>	<b>NPT, BSP</b>
-425 to +100 (-254 to +38)	1440 (99.3)	1440 (99.3)	275 (19.0)	720 (49.6)	3600 (248.2)
-20 to +200 (-29 to +93)	1240 (86.1)	1240 (86.1)	235 (16.5)	620 (43.0)	3095 (215.1)
-20 to +300 (-29 to +149)	1120 (77.1)	1120 (77.1)	215 (14.8)	560 (38.6)	2795 (192.9)
-20 to +400 (-29 to +204)	1025 (70.9)	1025 (70.9)	195 (13.6)	515 (35.5)	2570 (177.4)

\* For Temperatures below -20°F - refer to page 7 for Design Pressure Rating at Min. Temperature.

<b>TABLE DAG-1F</b>				
<b>DESIGN OUTLET PRESSURE FOR DA4</b>				
<b>in PSIG (BARG)</b>				
<b>CONSTRUCTION</b> *	<b>END CONNECTIONS</b>			
	<b>STD</b> <b>DIAPHRAGM</b>	<b>ALL</b>		<b>Opt-81 (Full Support Diaph)</b> <b>DA4</b>
<b>DESIGN TEMP.</b> <b>RANGE: Deg F</b> <b>(Deg C)</b>	<b>NPT, BSP,</b> <b>600#, EXTD</b> <b>NIPP, TUBE</b>	<b>150#</b>	<b>300#</b>	<b>NPT, BSP</b> <b>600#, EXTD NIPP, TUBE</b>
-425 to +100 (-254 to +38)	625 (43.0)	275 (19.0)	625 (43.0)	1125 (77.5)
-20 to +200 (-29 to +93)	620 (42.3)	235 (16.5)	620 (42.3)	1125 (77.5)
-20 to +300 (-29 to +149)	560 (38.6)	215 (14.8)	560 (38.6)	1120 (77.0)
-20 to +400 (-29 to +204)	515 (35.5)	195 (13.6)	515 (35.5)	1025 (70.9)

\* For Temperatures below -20°F - refer to page 7 for Design Pressure Rating at Min. Temperature.

**NOTE 1:** These pressure ratings may be further derated by limitations thru the Pressure Equipment Directive (97/23/EC-May '97). Whenever body and topworks are mixed, the P vs. T ratings that should be applied are those which are lowest for the two materials. **Example:** 300 lb. RF flanged SST body, standard diaphragm construction, at 200 deg F maximum temp would have a preliminary inlet and outlet to 620 psig, but if fitted with a ductile iron topworks pressure rating is only 400 psig. Must derate both the inlet and outlet to 400 psig. (Note: Topworks pressure rating, same as NPT design outlet pressure rating for the selected topworks material and diaphragm type.

The ratings are the same as above, if substitute steel topwork material.

Maximum Design Pressure Rating for 2" Opt -41 limited by 0.065" wall thickness to 1200 psig.

300# Flanges are derated due to the bolting for these products.

**Body Material Specifications**

**Cast Hastelloy** A494 Gr.CW-12MW or Hastelloy Weldment A494 Gr. CW-12MW w/ forged flanges B462 Gr. N10276

**Topworks Material Specifications**

Cast Steel A216 Gr. WCB

**DESIGN PRESSURE vs. TEMPERATURE vs END CONNECTION RATINGS**

(Per ASME B16.5 and B16.34) See NOTE 1

<b>TABLE DAG-1G</b>			
<b>DESIGN INLET PRESSURE FOR DA4</b>			
<b>in PSIG (BARG)</b>			
<b>CONSTRUCTION</b>	<b>END CONNECTIONS</b>		
	<b>STD DIAPHRAGM</b>		
<b>DESIGN TEMP. RANGE: Deg F (Deg C)</b>	<b>NPT, BSP</b>	<b>150#</b>	<b>300#</b>
-325 to +100 (-198 to +38)	1200 (82.7)	230 (15.9)	600 (41.4)
-20 to +200 (-29 to +93)	1105 (76.4)	210 (14.7)	550 (38.2)
-29 to +300 (-29 to +149)	1040 (71.8)	200 (13.7)	520 (35.9)
-20 to +400 (-29 to +204)	980 (67.6)	190 (12.9)	490 (33.8)

<b>TABLE DAG-1H</b>			
<b>DESIGN OUTLET PRESSURE FOR DA4</b>			
<b>in PSIG (BARG)</b>			
<b>CONSTRUCTION</b>	<b>END CONNECTIONS</b>		
	<b>STD DIAPHRAGM</b>		
<b>DESIGN TEMP. RANGE: Deg F (Deg C)</b>	<b>NPT, BSP</b>	<b>150#</b>	<b>300#</b>
-325 to +100 (-198 to +38)	625 (43.0)	230 (15.9)	600 (41.4)
-20 to +200 (-29 to +93)	550 (38.2)	210 (14.7)	550 (38.2)
-20 to +300 (-29 to +149)	520 (35.9)	200 (13.7)	520 (35.9)
-20 to +400 (-29 to +204)	490 (33.8)	190 (12.9)	490 (33.8)

**NOTE 1:** These pressure ratings may be further derated by limitations thru the Pressure Equipment Directive (97/23/EC-May '97).

**TABLE DAG-2  
MAXIMUM PRESSURE DROP FOR  
COMPOSITION SEATS**

Body Size		Max. Pressure Drop - psid (Bard)											
		Seat Material											
in	(DN)	BC, NBR, POLYALL *, FKM						GF-TFE					
		Liquid *		Gas		Steam	Liquid *		Gas		Steam √		
1/2" - 1"	(15-25)	600	(41.3)	750	(51.7)	DNA		450	(31.0)	1000	(68.9)	150/125	(10.3/8.6)
1-1/4" - 1-1/2"	(32-40)	600	(41.3)	600	(41.3)	DNA		450	(31.0)	900	(62.0)	150/125	(10.3/8.6)
2"	(50)	600	(41.3)	600	(41.3)	DNA		450	(31.0)	750	(51.7)	150/125	(10.3/8.6)
2-1/2" - 4"	(65-100)	500	(34.4)	600	(41.3)	DNA		450	(31.0)	750	(51.7)	125	(8.6)
		V-TFE						CTFE					
1/2" - 1"	(15-25)	300	(20.7)	600	(41.3)	125	(8.6)	600	(41.3)	3000	(206.9)	DNA	
1-1/4" - 1-1/2"	(32-40)	300	(20.7)	600	(41.3)	125	(8.6)	600	(41.3)	3000	(206.9)	DNA	
2"	(50)	300	(20.7)	600	(41.3)	125	(8.6)	600	(41.3)	2000	(137.9)	DNA	
2-1/2" - 4"	(65-100)	300	(20.7)	450	(31.0)	125	(8.6)	500	(34.4)	1500	(103.4)	DNA	

\* Only seat material to be applied in liquid "partially cavitating" service is PolyAll.  
√ Steam Service: metal diaphragm/composition diaphragm.  
N/A = Not Available  
DNA = Do Not Apply

**TABLE DAG-3  
MAXIMUM PRESSURE DROP FOR  
DYNAMIC SEAL DESIGNS**

Body Size		Max. Pressure Drop - psid (Bard)																
		Dynamic Seal Design																
in	(DN)	"OR" - O-RING *					"CP" - TFE CAP					"CW" - TFE CAP w/WIPER						
		Liquid *		Gas *		Steam	Liquid		Gas		Steam	Liquid		Gas		Steam		
1/2" - 1"	(15-25)	600	(41.3)	750	(51.7)	DNA		600	(41.3)	600	(41.3)	DNA		450	(31.0)	600	(41.3)	DNA
1-1/4" - 1-1/2"	(32-40)	600	(41.3)	750	(51.7)	DNA		600	(41.3)	600	(41.3)	DNA		450	(31.0)	600	(41.3)	DNA
2"	(50)	600	(41.3)	750	(51.7)	DNA		600	(41.3)	600	(41.3)	DNA		450	(31.0)	600	(41.3)	DNA
2-1/2" - 4"	(65-100)	600	(41.3)	750	(51.7)	DNA		600	(41.3)	600	(41.3)	DNA		450	(31.0)	600	(41.3)	DNA
		"PR" - PISTON RING ASSY.					"PW" - PISTON RING ASSY. w/WIPER					"UC" - U-CUP						
1/2" - 1"	(15-25)	DNA		DNA		√ 150/125	(10.3/8.6)	DNA		DNA		√ 150/125	(10.3/8.6)	600	(41.3)	3000	(206.9)	DNA
1-1/4" - 1-1/2"	(32-40)	DNA		DNA		√ 150/125	(10.3/8.6)	DNA		DNA		√ 150/125	(10.3/8.6)	600	(41.3)	3000	(206.9)	DNA
2"	(50)	DNA		DNA		√ 150/125	(10.3/8.6)	DNA		DNA		√ 150/125	(10.3/8.6)	600	(41.3)	3000	(206.9)	DNA
2-1/2" - 4"	(65-100)	DNA		DNA		125	(8.6)	DNA		DNA		125	(8.6)	600	(41.3)	3000	(206.9)	DNA

\* Only seat material to be applied in liquid "partially cavitating" or "flashing" service is PolyAll.  
√ Steam Service: metal diaphragm/composition diaphragm.  
N/A = Not Available    DNA = Do Not Apply    wo/ = without    w/ = with

**TABLE DAG-4  
MAXIMUM PRESSURE DROP FOR  
BASIC TRIM MATERIAL**

Body Size		Max Pressure Drop - psid (Bard)							
		Basic Trim Material							
in	(DN)	"P" - 17-4PH SST		"S" - 316L SST		"M" - Monel		"T" - Hybrid *	
1/2" - 2"	(15-50)	3000	(206.9)	800	(55.1)	1500	(103.4)	3000	(206.9)
2-1/2" - 4"	(65-100)	3000	(206.9)	800	(55.1)	1500	(103.4)	3000	(206.9)

\* 17-4PH SST plug & piston, Monel cage.

**TABLE DAG-5  
TEMPERATURE LIMITS  
FOR ELASTOMERIC MATERIALS**

Elastomer			T Maximum		T Minimum	
	ID	Description	°F	(°C)	°F	(°C)
	<b>Seats</b>	PolyAll	Proprietary Polyurethane Derivative	225°	(107°)	-60°
GF-TFE		Glass-filled Polytetrafluorethylene	425°	(218°)	-325°	(-198°)
V-TFE		Virgin TFE	400°	(205°)	-325°	(-198°)
CTFE		Chlorotrifluoroethylene TFE	300°	148°	-325°	(-198°)
BC		Neoprene	225°	(107°)	-35°	(-37°)
NBR		Buna-N	320°	(160°)	-40°	(-40°)
FKM		Fluorocarbon Elastomer	400°	(205°)	-20°	(-28°)
<b>Diaphragms</b>	3-Ply	3-Ply TFE/FKM/TFE	400°	(205°)	0°	(-17°)
	BC	Neoprene (Polychloroprene)	250°	(121°)	-65°	(-53°)
	EPR	Ethylene Propylene	300°	(148°)	-40°	(-40°)
	FK	Fluorosilicone	350°	(177°)	-65°	(-54°)
	FKM	Fluorocarbon Elastomer	400°	(205°)	0°	(-17°)
	NBR	Buna-N (Nitrile)	250°	(121°)	-70°	(-56°)
	FKM+TFE	Fluorocarbon Elastomer + TFE	400°	(205°)	0°	(-17°)
<b>Static Seals</b>	RTFE	Bronze-filled TFE	425°	(218°)	70°	(21°)
	V-TFE	Virgin TFE	400°	(205°)	-325°	(-198°)
	EPR	Ethylene Propylene	300°	(148°)	-40°	(-40°)
	FK	Fluorosilicone	350°	(177°)	-65°	(-54°)
	FKM	Fluorocarbon Elastomer	400°	(205°)	-20°	(-28°)
	NBR	Buna-N	212°	(100°)	-40°	(-40°)
	SST/TFE	301/302 SST U-cup / TFE	400°	(205°)	-325°	(-198°)
	HC/TFE	Hastelloy C U-cup / TFE	400°	(205°)	-325°	(-198°)
<b>Dynamic Seals</b>	"PR"	Piston Ring Assy, GF-TFE / SST	425°	(218°)	-40°	(-40°)
	"PW"	PRA* w/Wiper, GF-TFE / SST / GF-TFE	425°	(218°)	70°	(21°)
	"CW" – EPR/TFE	TFE Cap Seal, EPR O-ring, GF-TFE Wiper	300°	(148°)	-40°	(-40°)
	"CW" – NBR/TFE	TFE Cap Seal, NBR O-ring, GF-TFE Wiper	212°	(100°)	-40°	(-40°)
	"CW" – FK/TFE	TFE Cap Seal, FK O-ring, GF-TFE Wiper	350°	(177°)	-40°	(-40°)
	"CW" – FKM/TFE	TFE Cap Seal, FKM O-ring, GF-TFE Wiper	400°	(205°)	-20°	(-28°)
	"CP" – EPR/TFE	TFE Cap Seal, EPR O-ring	300°	(148°)	-40°	(-40°)
	"CP" – NBR/TFE	TFE Cap Seal, NBR O-ring	212°	(100°)	-40°	(-40°)
	"CP" – FK/TFE	TFE Cap Seal, FK O-ring	350°	(177°)	-10°	(-23°)
	"CP" – FKM/TFE	TFE Cap Seal, FKM O-ring	400°	(205°)	-20°	(-28°)
	SST/TFE	301/302 SST U-cup / TFE	400°	(205°)	-325°	(-198°)
	HC/TFE	Hastelloy C U-cup / TFE	400°	(205°)	-325°	(-198°)
	ELG/TFE	Elgiloy / TFE U-cup	400°	(205°)	-325°	(-198°)

\* PRA - Piston Ring Assembly

Metal Diaphragm		T Maximum		T Minimum	
ID	Description	°F	(°C)	°F	(°C)
BE-CU	Beryllium Copper	400°	(205°)	-325°	(-198°)

ABBREVIATIONS			
FK = Fluorosilicone	NBR = Buna-N	PTFE = Polytetrafluoroethylene	PRA = GF-TFE/SST
FKM = Fluorocarbon Elastomer	RTFE = Brz-fill TFE	V-TFE = Virgin TFE	BC = Neoprene
EPR = Ethylene Propylene	GF-TFE = Glass-fill TFE	CTFE = Chlorotrifluoroethylene TFE	ELG = Elgiloy

**TABLE DAG-6  
REDUCER MAXIMUM CAPACITY WITH PLUG WIDE-OPEN**

Body Size		Full Port Max Capacity		Full Port Max Capacity	
in	(DN)	Cv	Kv	Cv	Kv
1/2"	(15)	4.0	3.4	3.5	3.0
3/4"	(20)	8.0	6.9	3.5	3.0
1"	(25)	15	13	3.5	3.0
1-1/4"	(32)	23	20	6.0	5.2
1-1/2"	(40)	30	26	6.0	5.2
2"	(50)	60	52	12	10.4
2-1/2"	(65)	90	78	X	
3"	(80)	120	104		
4"	(100)	220	190		
<b>Diaphragm</b>		<b>Composition</b>		<b>Metal</b>	

**NOTE:** The above Cv factors may be used for sizing of safety relief valves or rupture discs.

**TABLE DAG-8  
PRESSURE LOADING OR PILOT SYSTEMS  
MAXIMUM CONTAINMENT PRESSURE PROCESS OR AUXILIARY FLUIDS**

TUBE	FITTINGS	PRESSURE		TEMPERATURE	
		psig	(Barg)	°F	(°C)
CU*	BR	1400	(96.5)	-325 to +100	(-198 to +37.7)
		1140	(78.6)	200	(93.3)
		1100	(75.8)	300	(148.8)
		700	(48.2)	400	(204.4)
		3300	(227)	-325 to +400	(-198 to +204.4)
SST^	SST	3300	(227)	-325 to +400	(-198 to +204.4)

\*1/4" O.D. X 0.030" Wall Thickness

^1/4" O.D. X 0.028" Wall Thickness

**Application Notes:**

1. For CU+BR System - if P1 pressure exceeds above limits, tubing & fittings materials as well as other system components MUST be switched over to SST materials.
2. Consult Factory for T1<0° F.
3. Use Heat Exchange "coils" when loading fluid (process, auxiliary) T1>140°F
4. Use Heat Exchange "coils" when T1<0°F
5. Other components of a given loading or piloting system may have lower limits of pressure or temperature than the tubing & fittings.

**TABLE DAG-9  
REDUCER – LOWER PISTON SPRING RANGES**

Basic Unit		Lower Piston Spring Range psig	Application Notes
Model	Diaphragm		
DA4 (formerly DA3)	Both	N/A	–
DA4	Comp	1–2	Pressure Loaded; P <sub>2</sub> ≤ 10 psig
		2–5	Pressure Loaded; P <sub>2</sub> > 5 psig
	Both	4–10	Pilot Operated
	Metal	4–10	Pressure Loaded; P <sub>2</sub> ≥ 10 psig

- NOTES:**
1. All metallic diaphragm constructions MUST include a lower piston spring.
  2. The 1–2 psig lower piston spring should only be used with low pressure setpoints. (P<sub>sp</sub> ≤ 10 psig) and with composition diaphragms.
  3. The 2–5 psig lower piston spring is –
    - most commonly selected,
    - recommended for P<sub>2</sub> > 10 psig or ΔP<sub>DIFF</sub> > 10 psid,
    - recommended for GF-TFE and CTFE seats,
    - recommended for tighter shutoff; i.e. lowest inboard leakage.
  4. Lower spring material matches main metallic trim in corrosion resistance.

**TABLE DAG-10  
INBOARD LEAKAGE RATINGS \*  
Per ANSI/FCI 70-2**

Seat Material	Dynamic Seal	
	O-Ring	Dynamic Seals Except O-Ring
CTFE, GF-TFE, and V-TFE	IV	IV
BC, NBR, PolyAll, FKM	VI	IV
*Inboard leak rates are the composite leakage of the seat leakage + dynamic seal leakage, considered as a single inboard leakage value.		

**TABLE DAG-11  
REDUCER RECOMMENDED VELOCITY LIMITS**

Application Fluid	Valve		Valve Body Outlet		Downstream Pipe		Units
	Type	Size Range	Recommend	Max.	Recommend	Max.	
Liquid	PRV	1/2"-4"	15	20	5-8	16	Ft/Sec
		6"	15	25	7-12	20	
		8"-12"	-	-	9-14	24	
Gas	PRV	1/2"-1"	0.20	0.40	0.15	0.30	Mach #
		1-1/4"-2"	0.25	0.45	0.20	0.30	
		2-1/2"-6"	0.30	0.50	0.25	0.35	
		8"-12"	-	-	0.25	0.40	
Steam	PRV	1/2"-1"	0.20	0.30	0.10	0.30	Mach #
		1-1/4"-2"	0.22	0.32	0.12		
		2-1/2"-6"	0.25	0.35	0.20		
		8"-12"	-	-	0.22		
<b>NOTES:</b> <ol style="list-style-type: none"> <li>Liquids experiencing no 2-phase flow at valve outlet will have same valve body outlet velocity as inlet velocity.</li> <li>Liquids experiencing 2-phase flow at valve outlet should have average velocity less than 150-200 ft/sec.</li> <li>Liquids experiencing 2-phase flow at outlet pipe should have average velocity less than 20-50 ft/sec.</li> <li>If valve outlet exceeds recommended limits, then can use external sensing to reach maximum limits.</li> <li>On gas service, a pilot operated prv can work with a outlet Mach = 0.75.</li> </ol>							

**TABLE DAG 13  
MAXIMUM RECOMMENDED NOISE LIMITS \***

Criteria	Body Sizes		Noise Level - dBA
	in	(DN)	
Per OSHA Regs. w/noise attenuation methods incorporated.	All	All	85-95
Sch. 80 pipe, no insulation.	1/2"-2"	(15-50)	95
Std. wt. pipe, no insulation.	2-1/2"-4"	(65-100)	98
* Consult Factory for ALL applications exceeding 97 dBA noise prediction.			

**Schemes To Reduce High Noise –**

- Staging – using two separate throttling valves in series.
- dB Plates – using 1, 2 or 3-stage dB Plate cartridges downstream of a throttling valve.
- Paralleling – using two separate throttling valves in parallel.
- Combinations – using multiple methods of above three possibilities.

**TABLE DAG-14**  
**RECOMMENDED INTERNAL MATERIALS**  
**For P<sub>max</sub>, Reference Individual Technical Bulletins**

	LIQUIDS			
	Fluid	Tmax °F	Tmin °F	Metal Trim
LIQUIDS	<b>Industrial Water – Cold</b>	180°	32°	P1
	Hot	225°	32°	P4
	DI, DM	225°	32°	PJ
		250°	32°	PL
	Seawater	180°	-20°	MQ, MW
	<b>Fuel Oils – Diesel, #1,#2‡</b>	180°	-30°	P5
	Bunker C, #3 - #6‡	180°	-30°	P5
		400°	0°	PC
	Jet Fuel JP3, JP4, JP5, JP6‡	400°	0°	PC
	Kerosene‡	400°	0°	PC
	<b>Crude Oils – Sweet‡</b>	225°	0°	PA
		400°	0°	PC
	Sour‡	225°	0°	NS
	<b>Heat Transfer Oils – Dowtherm, Therminol, Mobil-Therm, Silvatherm</b>	400°	0°	PC
	<b>Misc. Oils – Lube Oil‡</b>	180°	-30°	P5
Naptha‡	400°	0°	PC	
Turbine Oil‡	225°	0°	PA	
<b>Edible Oils – Vegetable Oil‡</b>	180°	-30°	PH	
Animal Fats‡	180°	-30°	PH	
Seed Oils‡	180°	-30°	PH	
LIQUIDS	<b>Inorganic Acids – Acetic - 5%</b>	100°	0°	SL
	Acetic - 30%	100°	0°	SL
	Sulfuric - conc.	100°	0°	CF *
	Sulfuric - dilute	100°	0°	CF *
	Nitric - conc.	140°	0°	SL
	Nitric - dilute	140°	0°	SL
	Hydrofluoric (air free) - dilute, concentrate	100°	0°	CF *
	Hydrobromic	140°	0°	CF *
	Phosphoric - dilute, concentrate	150°	0°	SL
	<b>Misc. Liquids – Gasoline‡</b>	150°	-30°	P5
	Benzene (C <sub>6</sub> H <sub>6</sub> )‡	150°	0°	SL
	Chlorine (Cl <sub>2</sub> )	150°	0°	ML
	Bromine (Br <sub>2</sub> )	150°	0°	CF *
	Ammonia (NH <sub>3</sub> )	140°	0°	SL
	Hydrogen Peroxide (H <sub>2</sub> O <sub>2</sub> )	125°	0°	SL
Hydrogen Chloride (HCl)	125°	0°	ML	
Hydrogen Bromide (HBr)	125°	0°	SL	
Cane Sugar Liquor	180°	0°	PH	

‡ In accordance with ASME B31.3 "Process Piping", do not use Ductile Iron Body for hydrocarbon or flammable service with inlet pressures greater than 150 psig (10.3 Barg) or temperatures greater than 300 deg F (149 deg C).  
 \* CF = Consult Factory

	GASES			
	Fluid	Tmax °F	Tmin °F	Trim
Atmospheric Gases	<b>Atmospheric Gases – O<sub>2</sub> (GOX)</b>	225°	-60°	M7
		350°	-65°	M9
		350°	-325°	TN
	N <sub>2</sub> (GN <sub>2</sub> ), Air, Argon	180°	-60°	P2
		350°	-65°	P8
	CO <sub>2</sub> (dry)	180°	-40°	P6
CO <sub>2</sub> (wet)	180°	-40°	P5	
Process Gases	<b>Process Gases – Nat. Gas (Sweet)</b>	180°	-65°	P9
	Nat. Gas (Sour)	180°	-40°	NR
	LPG (propane)	180°	-40°	PH
	Ammonia	120°	-40°	CF *
	Hydrogen	180°	-325°	SN
	Helium	180°	-325°	SN
	Chlorine (dry)	200°	0°	ME
	Hydrogen Chloride (dry)	120°	-40°	SJ
	Hydrogen Bromide (dry)	120°	0°	PE
	Hydrogen Fluoride (dry)	120°	0°	PE
	Hydrogen Sulfide (dry)	140°	0°	NS
	Hydrogen Sulfide (wet)	140°	0°	NS
Sulfur Dioxide (dry)	120°	0°	PE	
STEAM	P1 ≤ 125 psig	350°	—	PG

## DAG-14 SUPPLEMENT CHEMICAL RESISTANCE

**General Statement:** Statements located within this technical bulletin concerning suitability of fluids with TFE materials are general statements, and should not be construed as recommendations. Any statements of suitability are the result of a compilation of various sources of information based on experience, tests, and published technical literature. No guarantee or warranty is in anyway implied for a given particular service or application.

**Additional Reference:** For an inclusive listing covering a broader range of service application fluids, reference "Handbook of Corrosion Resistant Piping", P.A. Schweitzer, Industrial Press or "Compass Corrosion Guide", 2nd Edition, K.M. Pruett, Compass Publications. This publication will include information based on the following fluid variables:

1. Solution concentration
2. Pressure
3. Temperature

### DAG-15 Inverse Sympathetic Ratio (ISR) - effect on regulator performance.

DA4 regulators utilize a top and bottom guide, "flow to open" trim design. The top guide also acts as a "balancing" piston to oppose the forces generated by the inlet pressure acting on the valve plug. A small residual imbalance between the piston and the valve plug helps to reduce seat leakage at high differential pressures across the seat joint. This same imbalance produces an Inverse Sympathetic Ratio, ISR effect, as the delta pressure across the seat (DP) changes. The magnitude of the ISR effect is given in Table DAG-15 for both the pressure reducing and back pressure designs.

TABLE DAG-15		
Body Size		PRV - DA1/DA2/DA4/DAP
in	(DN)	
1/2", 3/4", 1"	(15,20,25)	0.03
1-1/4", 1-1/2"	(32,40)	0.04
2"	(50)	0.02
2-1/2", 3", 4"	(65,80, 100)	0.054

A typical example of the ISR effect is the rise in outlet setpoint as the inlet pressure decays from a pressure vessel or compressed gas bottle. A 1" DA1 connected to a nitrogen bottle at 3000 psig can be adjusted to deliver downstream pressure, P2, of 100 psig. The P2 will rise to 181.48 psig as the compressed gas bottle pressure decays to 284 psig, because of the ISR effect. The calculation follows below:

$$P_{sp} = P_2 + (ISR \times \Delta P_1)$$

$$\Delta P_1 = \text{INITIAL INLET} - \text{FINAL INLET}. (3000 - 284) = 2716$$

$$P_2 = 100$$

$$ISR = 0.03 \text{ (1.0" DA1)}$$

$$P_{sp} = 100 + (0.03 \times 2716)$$

$$P_{sp} = 181.48$$

**NOTE:** For a rising DP across the seat, the ISR effect would cause a downward shift or offset in the setpoint.

If the ISR effect is unacceptable, then two regulators installed in series will greatly reduce the overall ISR effect. Overall ISR effect = ISR (first stage regulator) x ISR (second stage regulator). For example, in the same application of a N2 bottle source using two 1" DA1 regulators, the setpoint offset -  $0.03 \times 0.03 \times 2716 = 2.44$ . In summary, the outlet pressure will rise from 100 psig to 102.44 psig as the inlet pressure decays from 3000 psig to 200 psig.

In a similar manner the ISR effect will produce an offset between the loading pressure, PL, and the pressure setpoint of a dome loaded regulator. For example, a 4" DA4 with an inlet pressure, P1 of 300 psig and an outlet pressure, P2 of 50 psig would require a loading pressure,  $PL = (P_1 - P_2) \times ISR + P_2 = (300 - 50) \times 0.054 + 50 = 63.5$  psig. In addition, if the DP changes, then a setpoint offset would be observed with a constant loading pressure.



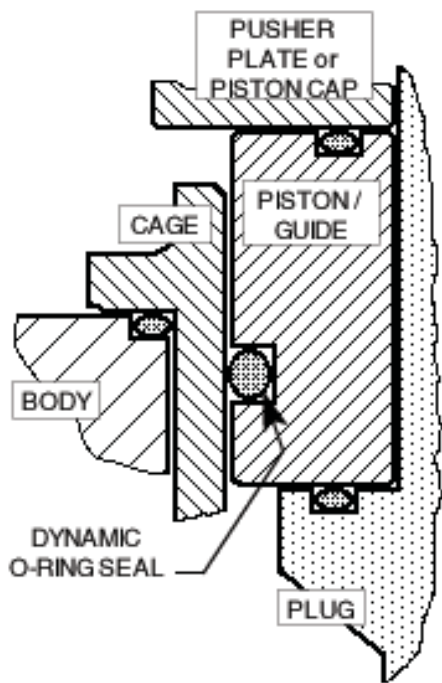

O-RING DYNAMIC SEAL

PRV, BPV

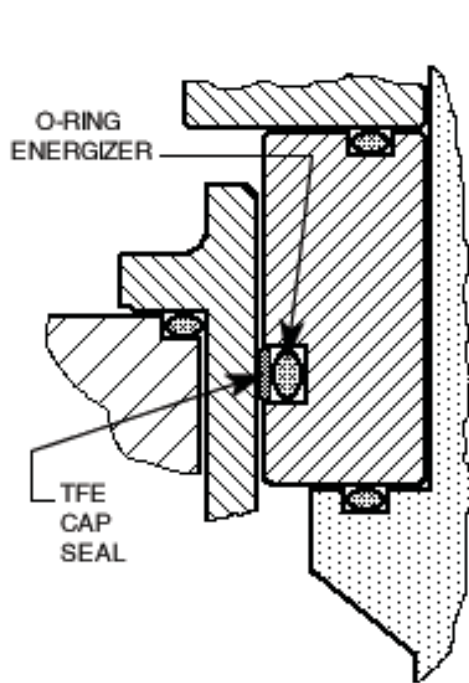

TFE CAP DYNAMIC SEAL

BPV

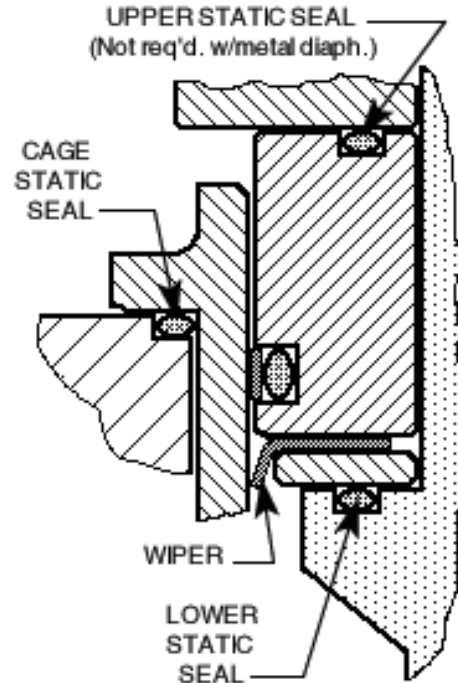

TFE CAP DYNAMIC SEAL + WIPER

PRV

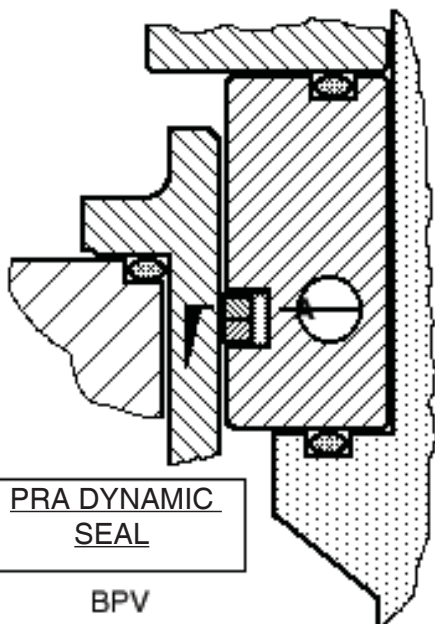

PRA DYNAMIC SEAL

BPV

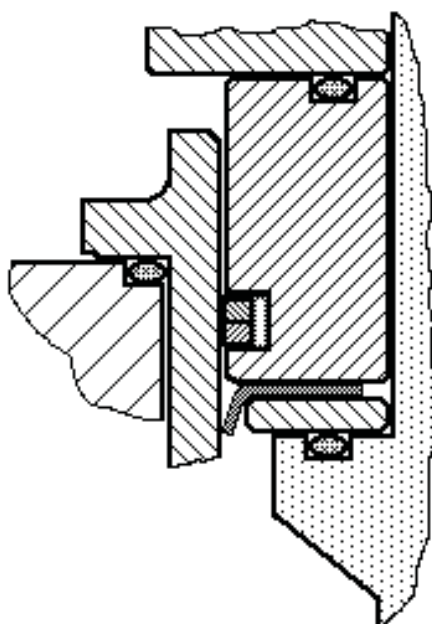

PRA DYNAMIC SEAL + WIPER

PRV

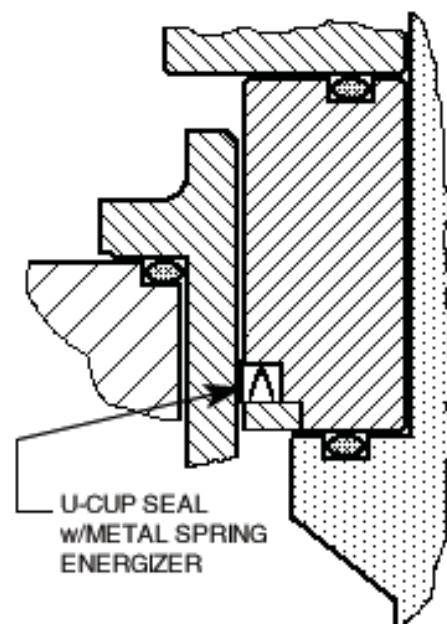

U-CUP SEAL w/METAL SPRING ENERGIZER

U-CUP DYNAMIC SEAL

PRV, BPV

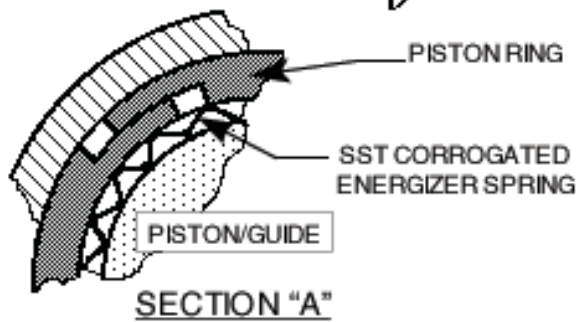

SECTION "A"

**FIGURE DAG-F1  
DYNAMIC & STATIC SEALS**

**FIGURE DAG-F2**  
**Location of BODY TAPS**

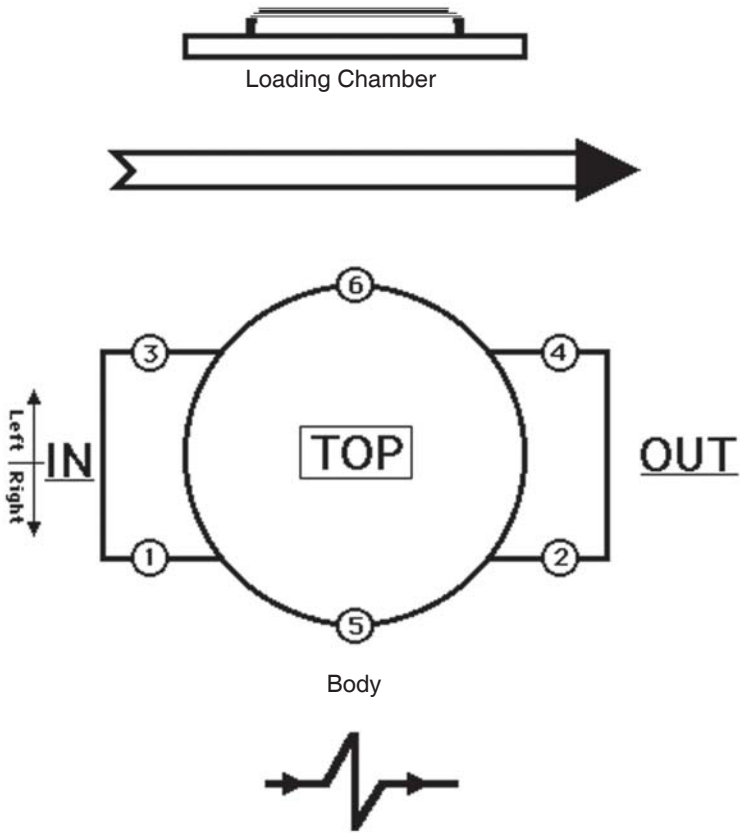

**Flow To Open Direction**

Location	Description	Opt. No.	NPT - Size	Body Mat'l.
1 & 2	Inlet & Outlet – Right	STD	1/4"	DI, CS & SST
1, 2 & 3	Inlet & Outlet – Right	STD	1/4"	BRZ
5	External Sensing – Right	STD	1/4"	DI, BRZ, CS & SST
1, 2, 3 & 4	Inlet & Outlet – Right Inlet & Outlet – Left	85	1/4"	DI, BRZ, CS & SST
5 & 6	Double External Sensing	85	1/4"	DI, BRZ, CS & SST

## DIMENSION and WEIGHTS

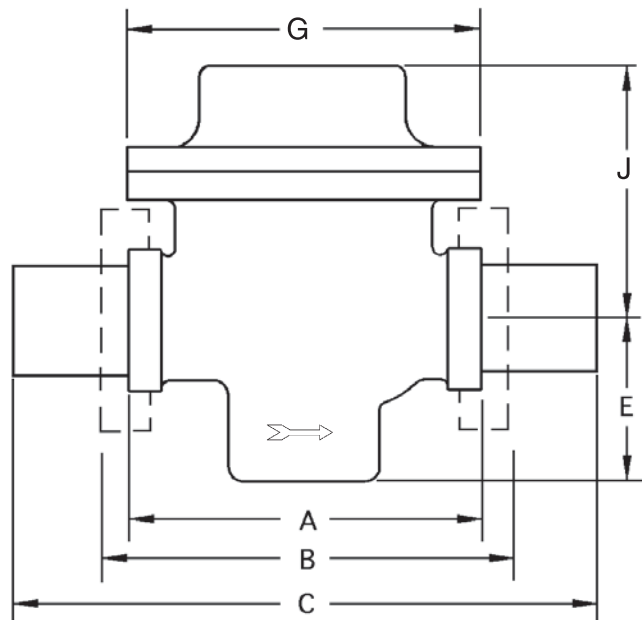

### ENGLISH UNITS (in) (lbs)

DIMEN.	END CONN.	BODY MAT'L	BODY SIZE					
			1/2", 3/4 & 1"	1-1/4" & 1-1/2"	2"	2-1/2"	3"	4"
A	NPT	DI, BRZ	6.00	9.88	9.88	-	-	-
		CS, SST, HC	8.25	9.88	9.75	-	-	-
B	125# FF	DI	-	-	-	10.88	11.75	13.88
	250# RF	DI	-	-	-	11.50	12.50	14.50
	150# FF	BRZ **	9.63	11.50 √	11.50	10.88	11.75	13.88
	300# FF	BRZ **	9.63	11.50 √	11.50	11.50	12.15	14.50
	150# RF	CS, SST	10.75	12.38 √	10.00	10.88	11.75	13.88
		HC*			13.75	-	-	-
	150# RF ‡	CS, SST	14.00	14.00 √	14.00	-	-	-
	300# RF	CS, SST,	10.75	12.38 √	10.50	11.50	12.50	14.50
		HC*			14.25	-	-	-
	300# RF ‡	CS, SST	14.00	14.00 √	14.00	-	-	-
600# RF	CS, SST	10.75	12.38 √	11.25	12.25	13.25	15.50	
600# RF ‡	CS, SST	14.00	14.00 √	14.00	-	-	-	
C	OPT-32 EXT NIPS	CS, SST	14.00	15.75	15.75	-	-	-
	OPT-41	SST	11.00	15.25	15.50	-	-	-
E	ALL	ALL	2.84	3.69	4.00	5.25	5.75	7.00
J	ALL	ALL	5.19	5.56	6.56	9.00	9.50	10.00
G	ALL	ALL	6.00	7.00	8.00	10.00	11.00	11.13
WEIGHT	wo/ Flanges	ALL	23	32	48	-	-	-
	w/ Flanges	ALL	28	42	61	90	155	164

### METRIC UNITS (mm) (kg)

END CONN.	BODY SIZE					
	DN15, DN20 & DN25	DN32 & DN40 √	DN50	DN65	DN80	DN100
NPT	152	251	251	-	-	-
	209	251	248	-	-	-
125# FF	-	-	-	276	298	352
250# RF	-	-	-	292	318	368
150# FF	246	292 √	292	276	298	352
300# FF	246	292 √	292	292	309	368
150# RF	273	314 √	254	276	298	352
			349	-	-	-
150# RF ‡	356	356 √	356	-	-	-
300# RF	273	314 √	267	292	318	368
			362	-	-	-
300# RF ‡	356	356 √	356	-	-	-
600# RF	273	314 √	286	311	336	394
600# RF ‡	356	356 √	356	-	-	-
OPT-32 EXT NIPS	356	400	400	-	-	-
OPT-41	279	387	394	-	-	-
ALL	72	94	102	133	146	178
ALL	132	141	167	229	241	254
ALL	152	178	203	254	279	283
wo/ Flanges	10	14	22	-	-	-
w/ Flanges	12	19	28	41	70	74

\* HC body material available in sizes 1", 1-1/2", & 2" ONLY.  
 \*\* Flanged BRZ bodies available in sizes 1", 1-1/2", 2", 2-1/2", 3", & 4" ONLY.  
 √ Flange Connection not available for 1-1/4" size.  
 ‡ Opt-34: Special 14" F to F Flange dimensions, CS and SST body material only.  
 Consult Factory for dimensions of ISO DIN Flanged units. (PN16, PN25, PN40)

The contents of this publication are presented for informational purposes only, and while every effort has been made to ensure their accuracy, they are not to be construed as warranties or guarantees, express or implied, regarding the products or services described herein or their use or applicability. We reserve the right to modify or improve the designs or specifications of such product at any time without notice.  
 Cashco, Inc. does not assume responsibility for the selection, use or maintenance of any product. Responsibility for proper selection, use and maintenance of any Cashco, Inc. product remains solely with the purchaser.

# MODEL DA4 PRODUCT CODER 03/14/16

An "X" in POS 12 followed by a 5-digit control number overrides remaining selections.

**D4** POS 3 — POS 5 POS 6 & 7 POS 8 — POS 10 POS 11 POS 12 **00** POS 15 POS 16 POS 17 **E**

POSITION 3 - SIZES			
Size		STD	OPT-81
in	(DN)	CODE	CODE
1/2"	(15)	4	J ^
3/4"	(20)	5	K ^
1"	(25)	6	L ^
1-1/4"	(32)	7	M ^
1-1/2"	(40)	8	N ^
2"	(50)	9	P ^
2-1/2"	(65)	A	NA
3"	(80)	B	NA
4"	(100)	C	NA

^ Not available with metal diaphragms.  
NA Not Available

POSITION 5 - BODY/COVER DOME MATERIALS			
Materials	CODE	Materials	CODE
DI/DI	1	SST/DI	7
BRZ/DI	2	SST/CS *	9
BRZ/BRZ	B	SST/SST *	A
CS/DI	4	Dup SST/CS * / **	F
CS/CS *	5	Dup SST/SST * / **	L
LCC/LCC *	6	Dup SST/Dup SST **	M
LCC/SST *	8	HC/CS ‡‡	G
		HC/SST ‡‡	H

\* For Opt-81 Select CS, LCC or SST Loading Chamber Material except in Canada, use SST. See Position 3  
\*\* Select for Sea water.  
‡‡ Sizes 1/2" - 2" Except No 1-1/4".

POSITION 6 & 7 - DIAPHRAGM, SEAL & SEAT MATERIALS					
Trim	Seat (#)	Diaphragm	Static Seal	Dynamic Seal	CODE
17-4PH SST "P"	PA	BC	NBR	O-ring	P1
	PA / (BC)	BC	NBR	SST/TFE u-cup	P2 / (PU)
	CTFE	BC	NBR	SST/TFE u-cup	P3
	PA	EPR	EPR	O-ring	P4
	PA	NBR	NBR	O-ring	P5
	PA / (NBR)	NBR	NBR	SST/TFE u-cup	P6 / (PW)
	PA	FK	FK	SST/TFE u-cup	P7 ‡
	GF-TFE	FK	FK	SST/TFE u-cup	P8 ‡
	V-TFE	FK	FK	SST/TFE u-cup	P9 ‡
	PA	FKM	FKM	O-ring	PA
	PA	FKM	FKM	SST/TFE u-cup	PB
	GF-TFE	FKM	FKM	O-ring	PC
	GF-TFE	FKM	FKM	SST/TFE u-cup	PD
	V-TFE	FKM + TFE	SST/TFE u-cup √	SST/TFE u-cup	PE
	GF-TFE	3-ply	RTFE	SST/TFE u-cup \$	PF
	GF-TFE	3-ply	RTFE	PRA + W \$	PG
	PA / (NBR)	NBR	NBR	TFE+NBR GFTFE CW	PH / (PY)
	PA	EPR	EPR	TFE+EPR GFTFE CW	PJ
	PA	FK	FK	TFE+FK GFTFE CW	PK
	GF-TFE	FKM	FKM	TFE+FKM GFTFE CW	PL
FKM	FKM	FKM	SST/TFE u-cup	PZ	
Monel "M"	PA	FK	FK	SST/TFE u-cup ‡‡	M7 ‡
	V-TFE	FK	FK	SST/TFE u-cup	M9 ‡
	V-TFE	FKM-TFE	SST/TFE u-cup √	SST/TFE u-cup	ME
	PA / (NBR)	NBR	NBR	TFE+NBR GFTFE CW	MH / (MY)
	PA	EPR	EPR	TFE+EPR GFTFE CW	MJ
	PA	FK	FK	TFE+FK GFTFE CW	MK
	GF-TFE	FKM	FKM	TFE+FKM GFTFE CW	ML
	V-TFE	FKM	FKM	O-ring	MQ
	NBR	NBR	NBR	O-ring	MW
	FKM	FKM	FKM	SST/TFE u-cup	MZ
	PA	FK	FK	SST/TFE u-cup	S7 ‡
	V-TFE	FK	FK	SST/TFE u-cup	S9 ‡
	PA	BE-CU *	SST/TFE u-cup	SST/TFE u-cup	SM
	V-TFE	BE-CU *	SST/TFE u-cup	SST/TFE u-cup	SN
	PA / (NBR)	NBR	NBR	TFE+NBR GFTFE CW	SH / (SY)
316L SST "S"	PA	EPR	EPR	TFE+EPR GFTFE CW	SJ
	PA	FK	FK	TFE+FK GFTFE CW	SK
	GF-TFE	FKM	FKM	TFE+FKM GFTFE CW	SL
	NBR	NBR	NBR	SST/TFE u-cup	SW
	PA	BC	V-TFE	ELG/TFE u-cup	NP ‡
	PA	NBR	NBR	ELG/TFE u-cup	NR
	PA	FKM	FKM	ELG/TFE u-cup	NS
	FKM	FKM	FKM	ELG/TFE u-cup	NF
	CTFE	NBR	V-TFE	ELG/TFE u-cup	NT ‡
	V-TFE	BC	VTFE	ELG/TFE u-cup	NV ‡
	PA	FK	FK	SST/TFE u-cup ‡‡	T7 ‡
	V-TFE	FK	FK	SST/TFE u-cup	T9 ‡
	PA	BE-CU *	SST/TFE u-cup	SST/TFE u-cup	TM
	V-TFE	BE-CU *	SST/TFE u-cup	SST/TFE u-cup	TN
	PA / (NBR)	NBR	NBR	TFE+NBR GFTFE CW	TH / (TY)
17-4PH/ Monel/ 17-4PH "T"	PA	EPR	EPR	TFE+EPR GFTFE CW	TJ
	PA	FK	FK	TFE+FK GFTFE CW	TK
	GF-TFE	FKM	FKM	TFE+FKM GFTFE CW	TL

‡‡ For GOX service, PA seats allowed in BRZ Bodies w/ trim materials "M" or "T" only.  
\* Metal diaphragm not available w/ Bronze Cover Dome or for sizes 2-1/2" - 4".  
‡ For Low Ambient Temperatures (See DAG-5 & -14 for Min. Temperatures).  
√ Sizes 2-1/2"-4" use V-TFE static seal. \$ For Steam Applications Max Press < 125 psig.  
(#) BC and NBR Seat material not available for 2-1/2" size.

POSITION 8 - Product Classification Under European "Pressure Equipment Directive"		
PRODUCT DESTINATION	HAZARD CATEGORY	CODE
Anywhere except Europe	N/A	7
European Countries * (CE Mark does not apply to DN25 and below)	Sound Engineering Practice (SEP)	S
	CE Marked Hazard Cat I or II	E

\* For products to be placed in service in Europe - Ref to Directive 97/23/EC. Forward Completed "EU" Application Recorder prior to quotation. (Without Recorder-Processing of Purchase Order will be delayed). Contact Cashco for Assistance.

POSITION 10 - END CONNECTIONS / ASME								
Size	Material	Method	End Conn	CODE	End Conn	CODE	End Conn	CODE
1/2" - 2"	ALL	-	NPT	1	-	-	-	-
2-1/2" - 4"	DI	Integral	125#FF	2	250#RF	3	-	-
1", 1-1/2" - 4"	BRZ	Integral	150#FF	6	300#FF	7	-	-
1/2" - 3/4"	CS,SST	Opt-30						
1" - 4"	CS-SST	Integral *	150#RF	4	300#RF	5	600# RF	8
1" - 2"	HC	Opt-30 *						
1/2" - 2"	ALL	Opt-31	BSP	P	-	-	-	-
1/2" - 2"	CS, SST	Opt-32	Extended Nipples			E		
1/2" - 2" (14" F to F)	CS, SST	Opt-34 *	150#RF	V	300#RF	W	600#RF	Y
1/2" - 1", 1-1/2" - 2"	SST	Opt-41	Non-High Purity Tube Ends		T	-	-	-

END CONNECTIONS FOR ISO DIN FLANGES				
DN15-25, 40, 50	BRZ	Integral	PN40 FF - will mate with PN16, 25 and 40	J
DN65-100			PN16 FF K PN25 FF L PN40 FF	M
DN15-25, 40, 50	CS, SST, HC	Opt-30	PN40 RF - will mate with PN16, 25 and 40	D
DN65-100	CS, SST	Integral	PN16 RF A PN25 RF C PN40 RF G	

\* Flanges Not Available for 1-1/4" (DN32) size.  
\*\* 1" size w/ 600# RF CS, or SST has weld-on flanges Opt-30 (Not available in HC material)

POSITION 11 - LOWER SPRING			
Model	Spring Range psig	Loading Method	CODE
DA4	No Spring *	Loaded	0 *
	2-5	Loaded	3
	1-2	Loaded	5
	4-10	Piloted	6
DA4 NACE	4-10	Loaded	N

\* Code formerly used for Model DA3 Composition Diaphragm Only

POSITION 12 - SENSING /LOADING CONFIGURATION (FLOW TO OPEN)		
Option	Sensing Only	Sensing WITH Loading Conf. *
Internal	1	A
External	2	B
Large Internal	4	C
For Special Construction Contact Cashco for Special Code		X

\* Requires Additional Loading Schematic. See Product Coders 92 thru 98.

POSITION 15 - BODY OPTIONS		
Option	CODE	
No Option	-	0
Second Set 1/4" (DN8) FNPT Pressure Taps & Plugs.	-85	T

POSITION 16 - CERTIFICATE OPTIONS		
Option	CODE	
No Option	-	0
NACE CONST: CS/CS, LCC/LCC, LCC/SST, SST/CS or SST/SST All Sizes (Except 1-1/4").	-40	J
Special Cleaning: Per Cashco Spec #S-1134. W/ properly selected mat'ls. Suitable for Oxygen Service. BRZ or SST body material.	-55	M
Special Cleaning: Per Cashco Spec #S-1542.	-56	N
Special Cleaning: Per Cashco Spec #S-1589 Cl <sub>2</sub> Service.	-57	P

POSITION 17 - PAINT OPTIONS		
Option	CODE	
No Option	-	0
Epoxy Painted Per Cashco Spec #S-1547.	-95	W
Epoxy Painted Per Cashco Spec #S-1687.	-95OS	Y

Cashco, Inc.  
P.O. Box 6  
Ellsworth, KS 67439-0006  
PH (785) 472-4461  
Fax. # (785) 472-3539  
www.cashco.com  
email: sales@cashco.com  
Printed in U.S.A. DA4-TB

Cashco GmbH  
Handwerkerstrasse 15  
15366 Hoppegarten, Germany  
PH +49 3342 30968 0  
Fax. No. +49 3342 30968 29  
www.cashco.com  
email: germany@cashco.com

Cashco do Brasil, Ltda.  
Al.Venus, 340  
Indaiatuba - Sao Paulo, Brazil  
PH +55 11 99677 7177  
Fax. No.  
www.cashco.com  
email: brazil@cashco.com